



ISO 9001
International Standards
Certifications

ISO 9001:2008

TEFPASS®

PTFE LINED PIPE & FITTINGS



PTFE內襯直管與管件規範.....	2
Specification for PTFE Lined Pipe and Fittings.....	4
PTFE Lined Pipe.....	6
PTFE Lined 90°Elbow.....	7
PTFE Lined 45°Elbow.....	8
PTFE Lined Equal Tee.....	9
PTFE Lined Reducing Tee.....	10
PTFE Lined Concentric Reducer..	12
PTFE Lined Eccentric Reducer..	14
PTFE Lined Cross.....	16
PTFE Lined Sight Glass.....	17
PTFE Lined Reducing Flange..	18
PTFE Lined Instrument Tee.....	20
Y-Tee.....	21
Bellows.....	22
High Pressure Bellows.....	23
Vacuum Resistant Bellows.....	24
Reinforced Bellows.....	25
Solid Spacer.....	26
Armored Spacer.....	26
Distance Spacer.....	27
PTFE Lined Blind Flange.....	27
Pipe Dimensions.....	28
ANSI Class 150lbs Flange Dimensions.....	28
JIS Class 10K Flange Dimensions.....	29
DIN PN16 Flange Dimensions...29	
管線組合安裝時注意要點.....	30
Instructions for Assembling Pipes and Fittings.....	31



上品公司自1981年9月成立，創始時是以氟素樹脂塗裝技術為基礎，經過逐年不斷技術開發、技術轉移以及新產品代理其他相關氟素產品，如製作鐵氟龍耐高溫輸送帶、氟素樹脂板片內襯、蛇管、熱交換器、內襯直管與管件，代理內襯球閥、柱塞閥與蝶閥，營業範圍由點線逐漸擴大到面。

更基於九〇年代後，半導體工業逐漸蓬勃發展，半導體製程對於氟素樹脂要求的質量與日俱增，上品公司亦開發PFA管、管件和PTFE內襯EL桶槽，並增設多套無塵室，最高等級為Class 1000，讓我們半導體製品都能符合半導體製程的潔淨要求。

我們以企業的永續經營為理念，非常重視客戶需求與品質的滿意度，在追求速度的二十一世紀，這樣的內部動力不斷地提升我們的技術、品質與新產品開發能力，所以我們和客戶之間都能達到互助互利的良好互動關係。

Allied Supreme Corp. has established since September of 1981. In the beginning of the business, we devoted ourselves on fluorocarbon coating application. Through technical transfer, continuous improvement, development and being agent of international brands, we have increased our product to various items. We manufacture Teflon conveyer belt, fluorocarbon sheet lining, flexible hose, heat exchanger, lined pipe & fitting as well as act as agent for Teflon lined ball valve, plug valve and butterfly valve. We have expanded our business rapidly.

Owing to the prosperous development of semi-conductor in late 1990, the requirement of quality fluorocarbon resin product keeps increasing. We have developed PFA tube, pipe and fitting and PTFE Lined EL tank and built Class 1000 clean rooms in compliance with the high purity requirement of semi-conductor industries. Our policy is to offer the best quality product and do every effort to satisfy customer. In the speeding 21 century, the concept encourages us to upgrade our know-how, product quality and R&D ability continuously. Through the efforts, we have established the good relationship and built the mutual benefits between our company and customers.

PTFE LINED PIPE & FITTINGS



PTFE

內襯直管與管件規範

1. 範圍

- 1.1 本規範適用於傳送腐蝕性流體之PTFE 內襯直管及管件。內容包括施工材料、尺寸以及標準的測試程序。
- 1.2 本內容包含ANSI 150 LBS 及 JIS 10K 規範的PTFE內襯直管、法蘭及管件。

2. 材料的結構

2.1 PTFE 特性

- 2.1.1 溫度限制
連續使用溫度 260° C
融點 327° C
- 2.1.2 耐化學性
能抵抗大部分的化學品，關於詳細之資料，請詢問本公司的銷售工程師。
- 2.1.3 磨擦係數
靜磨擦係數 0.10
動磨擦係數 0.05
- 2.1.4 比重 ASTM D792 2.14 ~ 2.2
- 2.1.5 抗拉強度 ASTM D638 > 210 kg /cm²
- 2.1.6 抗黏性
表面張力 18.5 dyne/cm
接觸角度
水 104° ~ 111°
十六烷 37° ~ 45°
- 2.1.7 延伸率 ASTM D638 > 250%
- 2.1.8 吸水性 ASTM D570 < 0.01%

2.2 PTFE 內襯

- 2.2.1 此內襯根據 ASTM D4894 之規範由聚四氟乙烯樹脂及少於總重量1% 之添加物所製成。
- 2.2.2 比重
此 PTFE 樹脂內襯根據ASTM D792 之規範，比重界於2.14 到 2.2 之間。

2.3 鐵件

- 2.3.1 碳鋼直管
直管由有縫或無縫鋼管製成,口徑 1/2" ~8"
依SCH40, 10" 以上依SCH20。
材料規範依 ASTM A53。
- 2.3.2 碳鋼管件
管件由無縫鋼管或鑄件製成, 口徑 1/2" ~10"
依SCH40, 12" 以上依STD。
材料規範依 ASTM A234或A395。
- 2.3.3 不鏽鋼直管
直管由有縫或無縫鋼管SCH20 製成。
(要更改為SCH40可和銷售工程師討論)。
材料規範依 ASTM A312。
- 2.3.4 不鏽鋼管件
管件由無縫鋼管製成1/2" ~10" 依SCH40, 12"
以上依STD。
材料規範依 ASTM A403。
- 2.3.5 法蘭
材料規範:
碳鋼 ASTM A105
不鏽鋼 ASTM A182
- 2.3.6 焊接
所有焊接製作根據 ASME Boiler 及 Pressure Vessel Code 之第九款的規定。
- 2.3.7 表面處理
所有的碳鋼鐵件外部採用噴砂及油漆，不鏽鋼依負銷售工程師和客戶的約定處理。

3. 設計要求

3.1 尺寸

3.1.1 PTFE 內襯直管之內襯厚度

單位：mm

尺寸	1/2"	3/4"	1"	1-1/2"	2"	2-1/2"	3"	4"	5"	6"	8"	10"	12"	14"	16"	18"	20"
標準管	3.0	3.0	3.0	3.0	3.0	3.0	3.0	3.0	3.0	4.0	5.5	6.0	6.0	6.5	7.0	9.0	-
厚管	-	-	-	-	4.0	4.0	5.0	5.0	5.0	5.5	7.0	9.0	10.5	-	11.0	-	12.0

註：其他不同於上述的PTFE內襯直管厚度需求，請洽本公司銷售工程師。

3.1.2 PTFE 內襯管件之內襯標準厚度

詳見本目錄內頁分項資料。

3.1.3.3 管件

根據ANSI B16.5

3.1.3 公差

直管，法蘭及管件之公差規定如下：

3.1.3.1 直管

長度公差 $\pm 1/8"$ ($\pm 3.2\text{mm}$)

兩端法蘭螺孔偏心公差 $\pm 1/16"$ ($\pm 1.6\text{mm}$)

3.1.3.2 法蘭

根據ANSI B16.5

3.2 排氣孔

每一直管及管件都有排氣孔以釋放內襯與鐵件之間的氣體。直管至少有兩個直徑0.12"(3mm)之排氣孔，位於兩端法蘭面2"(50mm)距離的位置；每一個管件至少有兩個排氣孔；漸縮法蘭則沒有排氣孔。

4. 檢驗要求

4.1 水壓測試

依需求的測試壓力，持壓3分鐘。

4.2 針孔測試

需通過20,000伏特電壓檢測。

4.3 外部油漆

碳鋼管件標準為底漆一道，面漆依需求另訂之，不銹鋼管件依訂單需求訂定。

5. 包裝方式

5.1 包裝

每一端之法蘭內襯面以木板或塑膠護蓋保護。

出貨國內以棧板為原則。

出貨國外以木箱為原則。

SPECIFICATION FOR PTFE LINED PIPE AND FITTINGS

1. SCOPE

- 1.1 This specification covers Polytetrafluoroethylene (PTFE) line pipe & fitting applied for conveying corrosive fluids. The contents include the requirement for construction of materials, dimensions together with standard test procedure.
- 1.2 This specification covers ANSI 150 LBS & JIS 10K PTFE lined pipe, flange and fittings.

2. CONSTRUCTION OF MATERIALS

2.1 THE PROPERTIES OF PTFE

- 2.1.1 Temperature limitation
Maximum continuous service temperature: 260°C
Melt point: 327°C
- 2.1.2 Chemical inertness
Resist to most of all chemicals. Please consult our sales engineer for information.
- 2.1.3 Coefficient of friction
Static coefficient of friction: 0.10
Kinetic coefficient of friction 0.05
- 2.1.4 Specific gravity ASTM D792 2.14 ~ 2.2
- 2.1.5 Tensile strength ASTM D638 > 210 kg /cm²
- 2.1.6 Non-stick
Surface tension 18.5 dyne/cm
Contact angle
Water 104° ~ 111°
Hexadecane 37° ~ 45°
- 2.1.7 Elongation ASTM D638 > 250%
- 2.1.8 Water absorption ASTM D570 < 0.01%

2.2 PTFE LINING

- 2.2.1 The lining is made from Polytetrafluoroethylene resins conforming to the requirement of specification ASTM D4894 and including less than 1 % weight of additives.
- 2.2.2 Specific gravity
The lining is made from PTFE resin meeting specification ASTM D792 which have a specific gravity in between 2.14 to 2.2.

2.3 HOUSING

- 2.3.1 Carbon steel straight pipe
Straight pipes are made of welded or seamless steel housing. For nominal sizes 1/2" ~ 8" are fabricated according to SCH 40; 10" and above are according to SCH 20. Material specifications are in compliance with ASTM A53.

- 2.3.2 Carbon steel fitting
Fittings are made of welded or casting iron steel housing. For nominal sizes 1/2" ~ 10" are fabricated according to SCH 40; 12" and above sizes are according to STD. Material specifications are in compliance with ASTM A234 or A395.
- 2.3.3 Stainless steel straight pipe
Straight pipes are made of welded or seamless steel housing according to SCH20. SCH40 is also available upon request, please consult our sales engineer for information. Material specifications are in compliance with ASTM A312.
- 2.3.4 Stainless steel fitting
Fittings are made of seamless pipe 1/2"~10" according to SCH40. For nominal sizes 12" and above are fabricated according to STD. Material specifications are in compliance with ASTM A403.
- 2.3.5 Flange
Flanges are made from below material specifications:
Carbon steel ASTM A105
Stainless steel ASTM A182
- 2.3.6 Welding
The welding fabrication is in accordance with Provision of section XI of ASME Boiler and Pressure Vessel Code.
- 2.3.7 Finish
The external surface of carbon steel housing needs to process sandblasting and painting works; the treatment of stainless steel shall be according to agreement between customer and sales engineer.

3. DESIGN REQUIREMENTS

3.1 DIMENSION

3.1.1 Nominal PTFE liner thickness of piping

Unit : mm

Size	1/2"	3/4"	1"	1-1/2"	2"	2-1/2"	3"	4"	5"	6"	8"	10"	12"	14"	16"	18"	20"
Standard wall	3.0	3.0	3.0	3.0	3.0	3.0	3.0	3.0	3.0	4.0	5.5	6.0	6.0	6.5	7.0	9.0	-
Heavy Wall	-	-	-	-	4.0	4.0	5.0	5.0	5.0	5.5	7.0	9.0	10.5	-	11.0	-	12.0

Note: Different thicknesses of PTFE liners are upon request, please consult our sales engineer for information.

3.1.2 PTFE wall thickness of fittings

Please refer to following specifications of the items in this catalogue.

3.1.3. Tolerances of pipe, flange and fitting are specified as follows :

3.1.3.1 Pipe

In Length $\pm 1/8(\pm 3.2 \text{ mm})$

Flange bolt hole alignment $\pm 1/16"(\pm 1.6 \text{ mm})$

3.1.3.2 Flange

See ANSI B16.5

3.1.3.3 Fitting

See ANSI B16.5

3.2 VENT HOLE

Each pipe & fitting is provided with a venting system that will release any gas between the liner and the housing. Each pipe will have at least 2 vent holes in diameter 0.12(3mm), located 2"(50mm) from the ends. Each fitting shall have two vent holes at least. As for reducing flange has no vent hole.

4. INSPECTION REQUIREMENTS

4.1 HYDROSTATIC PRESSURE TEST

The testing will be conducted by specified pressure standard and last for 3 minutes.

4.2 ELECTROSTATIC TEST

Conduct the test with holiday tester at an output of 20,000 V.

4.3 PAINTING INSPECTION

The criteria of carbon steel fittings are one primer coated, finish painting will depend on the actual requirements. Stainless steel is according to the order's specification.

5. PACKING METHOD

5.1 PACKING

The faces of each end are protected by wooden plates or plastic lids.

The consignment for inland transportation will be packed by pallets.

The consignment for overseas transportation will be packed by wooden cases.

PTFE Lined Pipe

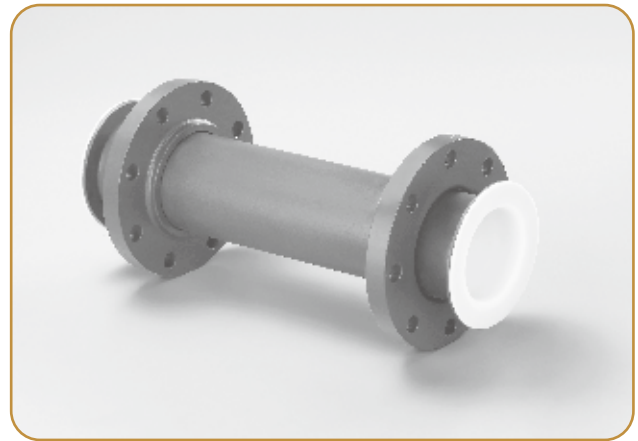
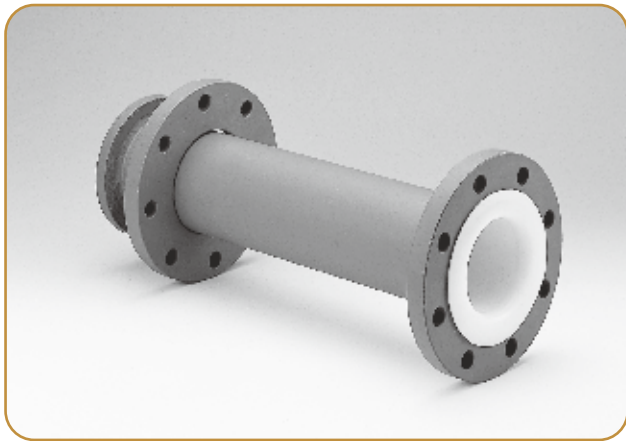

*** LF/FF(A)**

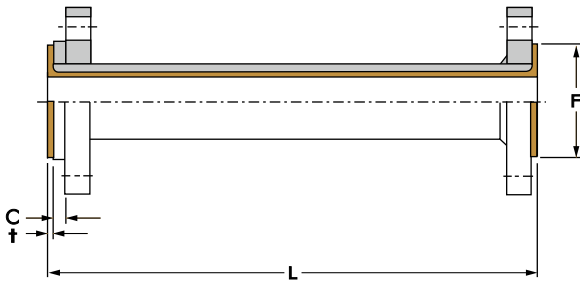

*** LF/LF(B)**

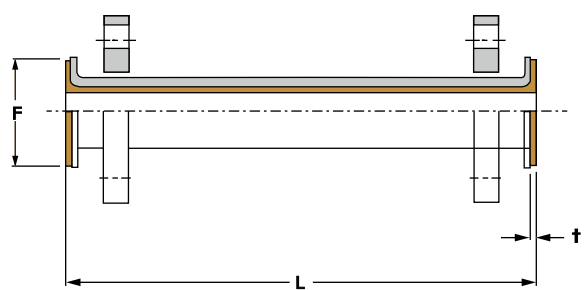

Flange: ANSI 150LBS

unit : mm

Nominal size		F	C	t		L(Min.)		L(Max.)	G.W. (kg)	
Inch	mm			Standard wall	Heavy wall	*LF/FF(A)	*LF/LF(B)		Standard wall	Heavy wall
1/2"	15	32	8	3	-	100	-	6000	1.61*M+1.2	-
3/4"	20	40	8	3	-	100	200	6000	2.14*M+2.0	-
1"	25	48	8	3	-	100	200	6000	2.99*M+2.2	-
1-1/2"	40	68	8	3	-	100	220	6000	4.84*M+3.1	-
2"	50	87	8	3	4	150	220	6000	6.47*M+4.6	6.77*M+4.6
2-1/2"	65	100	8	3	4	150	220	6000	10.03*M+7.1	10.43*M+7.1
3"	80	117	8	3	5	200	250	6000	12.83*M+8.7	13.23*M+8.7
4"	100	151	8	3	5	200	250	6000	18.46*M+12.4	18.96*M+12.4
5"	125	175	10	3	5	200	350	6000	32.91*M+17.6	34.21*M+17.6
6"	150	203	15	4	5.5	200	350	6000	42.60*M+15.8	44.4*M+15.8
8"	200	256	20	5.5	7	250	450	6000	48.72*M+26.8	50.22*M+26.8
10"	250	311	25	6	9	250	-	6000	50.60*M+37.5	52.60*M+37.5
12"	300	365	25	6	10.5	250	-	6000	60.30*M+62.0	65.10*M+62.0
14"	350	415	25	6.5	-	250	-	2000	81.50*M+76.0	-
16"	400	475	25	7	11	300	-	2000	97.5*M+96.2	99.5*M+96.2
18"	400	514	25	9	-	300	-	2000	117.9*M+102	-
20"	500	565	30	-	12	300	-	2000	-	158.0*M+141

Pipe : ASTM A53 grade B, in compliance with ANSI B36.10

Flange: ASTM A105, in compliance with ANSI B.16.5/Class 150lbs; JIS 10K; DIN or others is also available on request.

LF/LF; LF/FF or FF/FF are also available on request.

Lining: Pure PTFE in compliance with ASTM D4894, different PTFE Liner thickness.

Other sizes are available on request.

*LF/FF(A): Loose Flange-Fixed Flange.

*LF/LF(B): Loose Flange-Loose Flange (available from 3/4" to 8").

PTFE Lined 90° Elbow

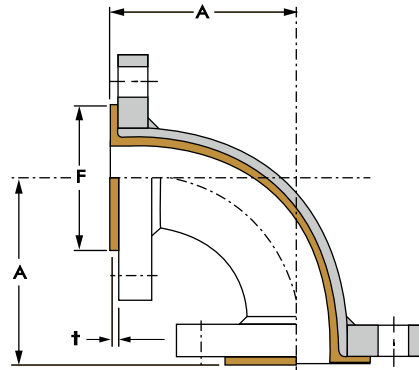
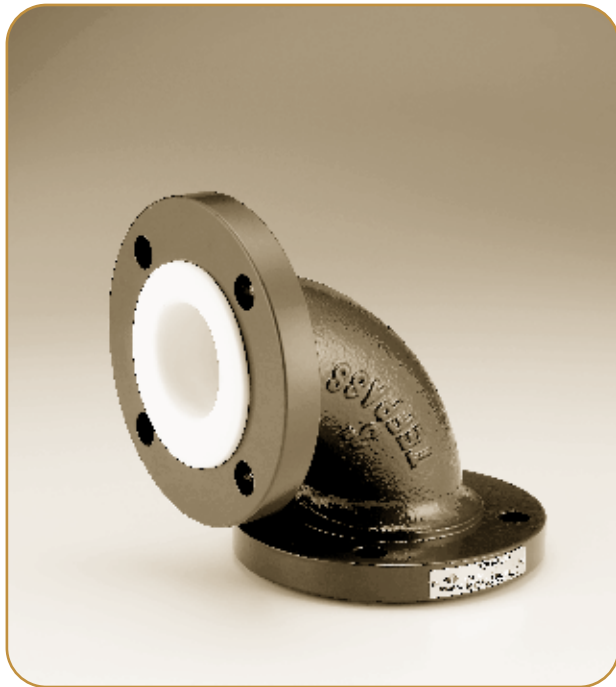

Flange: ANSI 150LBS

unit : mm

Nominal size		F	A	t		G.W. (kg)	
Inch	mm			Standard wall	Heavy wall	Standard wall	Heavy wall
1/2"	15	32	70	3	-	1.2	-
3/4"	20	40	80	3	-	1.8	-
1"*	25	48	89	3	-	3.0	-
1-1/2"*	40	65	102	3	-	4.0	-
2"*	50	87	114	3	4	7.0	7.2
2-1/2"	65	100	127	3	4	9.8	10.3
3"*	80	117	140	3	5	11.8	12.4
4"*	100	151	165	3	5	16.2	17.1
5"	125	173	190	4	7	22.5	23.5
6"*	150	203	203	4	7	26.0	27.3
8"	200	256	228	4	7.5	44.0	46.0
10"	250	311	280	5	9	67.0	69.0
12"	300	365	305	5	11	100.0	104.0
14"	350	415	356	5	11	140.0	147.0
16"	400	475	407	6	11	190.0	199.0
18"⊙	450	514	420	3	-	231.0	-
20"⊙	500	565	457	3	-	315.0	-

Steel frame: ASTM A234 grade WPB, in compliance with ANSI B16.28

Flange: ASTM A105, in compliance with ANSI B16.5/Class 150lbs; JIS 10K or DIN is also available on request.

Standard: Two fixed flanges; two loose flanges or one loose and one fixed flange are on request.

* : Ductile iron ASTM A395 and ASTM A234 Gr. WPB are both available.

⊙ : Fabricated by technique of sheet lining.

Lining: Pure PTFE in compliance with ASTM D4894.

Other sizes are available on request.

PTFE Lined 45° Elbow

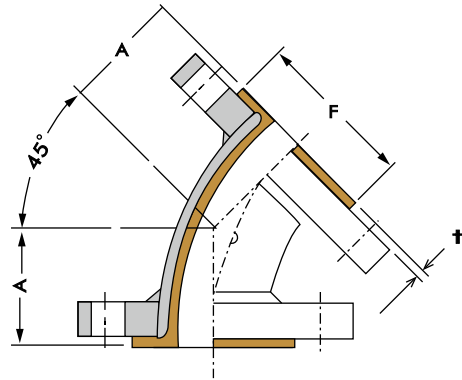
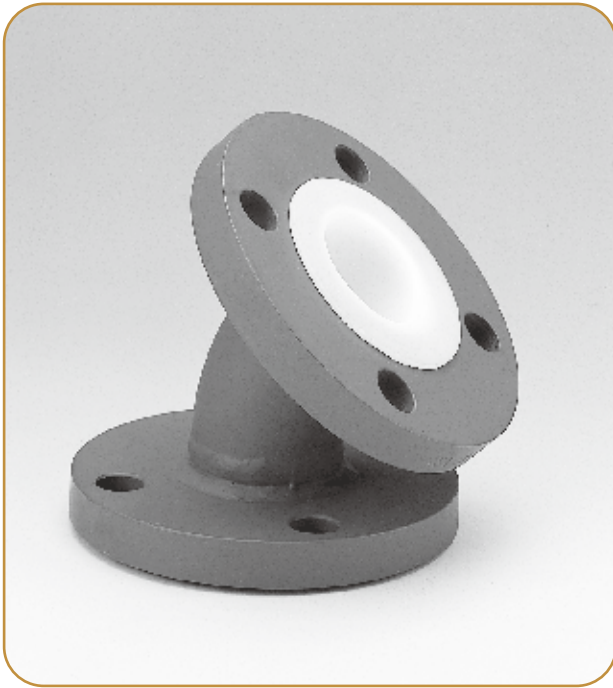

Flange: ANSI 150LBS

unit : mm

Nominal size		F	A	t		G.W. (kg)	
Inch	mm			Standard wall	Heavy wall	Standard wall	Heavy wall
1/2"	15	32	45	3	-	1.0	-
3/4"	20	40	45	3	-	1.6	-
1"	25	48	45	3	-	2.2	-
1-1/2"	40	65	58	3	-	3.6	-
2"	50	87	64	3	4	4.8	5.1
2-1/2"	65	100	76	3	4	8.4	8.8
3"	80	117	76	3	5	10.5	11.0
4"	100	151	102	3	5	14.6	15.2
5"	125	175	114	4	7	19.5	20.2
6"	150	203	127	4	7	25.1	26.0
8"	200	256	140	4	7.5	40.5	42.0
10"	250	311	165	5	9	56.0	57.5
12"	300	365	191	5	11	88.0	91.0
14"	350	415	191	5	11	110.0	115.5
16"	400	475	203	6	11	175.5	183.8
18"⊙	450	514	216	3	-	198.0	-
20"⊙	500	565	241	3	-	253.0	-

Steel frame: ASTM A234 grade WPB, in compliance with ANSI B16.28

Flange: ASTM A105, in compliance with ANSI B16.5/Class 150lbs; JIS 10K or DIN is also available on request.

Standard: Two fixed flanges; one loose and one fixed flange or two loose flanges are on request.

⊙ : Fabricated by technique of sheet lining.

Lining: Pure PTFE in compliance with ASTM D4894.

Other sizes are available on request.

PTFE Lined Equal Tee

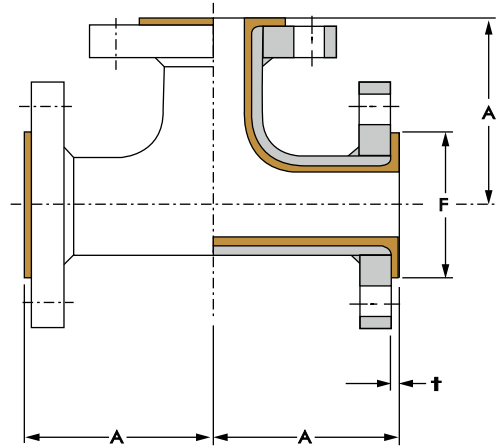

Flange: ANSI 150LBS

unit : mm

Nominal size		F	A	t		G.W. (kg)	
Inch	mm			Standard wall	Heavy wall	Standard wall	Heavy wall
1/2"	15	32	70	3	-	1.8	-
3/4"	20	40	80	3	-	2.5	-
1" *	25	48	89	3	-	3.4	-
1-1/2"	40	65	102	3	-	6.0	-
2" *	50	87	114	3	4	9.8	10.2
2-1/2"	65	100	127	3	4	14.2	14.7
3" *	80	117	140	3	5	16.6	17.2
4" *	100	151	165	3	5	25.8	26.6
5"	125	173	190	4	7	28.0	29.2
6"	150	203	203	4	7	41.2	42.9
8"	200	256	228	4	7.5	58.0	62.4
10"	250	311	280	5	9	104.0	108.6
12"	300	365	305	5	11	146.2	153.6
14"	350	415	356	5	11	209.0	219.0
16" ©	400	475	407	3	11	232.4	-
18" ©	450	514	420	3	-	268.8	-
20" ©	500	565	457	3	-	331.1	-

Steel frame: ASTM A234 grade WPB, in compliance with ANSI B16.28

Flange: ASTM A105, in compliance with ANSI B16.5/Class 150lbs; JIS 10K or DIN is also available on request.

Standard: Three fixed flanges; three loose flanges, one loose and two fixed flanges, two loose and one fixed flanges are on request.

* : Ductile iron ASTM A395 and ASTM A234 Gr. WPB are both available.

© : Fabricated by technique of sheet lining.

Lining: Pure PTFE in compliance with ASTM D4894.

Other sizes are available on request.

PTFE Lined Reducing Tee

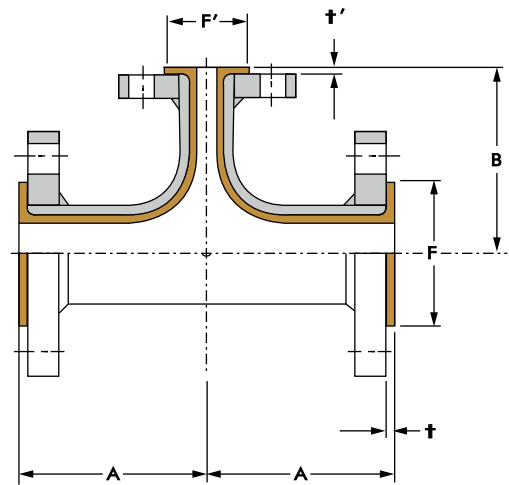

Steel frame: ASTM A234 grade WPB, in compliance with ANSI B16.28

Flange: ASTM A105, in compliance with ANSI B16.5/Class 150lbs; JIS 10K or DIN is also available on request.

Standard: Three fixed flanges; three loose flanges, one loose and two fixed flanges, two loose and one fixed flanges are on request.

© : Fabricated by technique of sheet lining.

Lining: Pure PTFE in compliance with ASTM D4894.

Other sizes are available on request.

Flange: ANSI 150 LBS

unit : mm

Nominal size		F	F'	A	B	†		†'		G.W. (kg)	
Inch	mm					S/W	H/W	S/W	H/W	S/W	H/W
1-1/2" x 1"	40 x 25	65	48	102	102	3	-	3	-	5.2	-
2" x 1"	50 x 25	87	48	114	114	3	4	3	-	7.2	7.5
2" x 1-1/2"	50 x 40	87	65	114	114	3	4	3	-	7.8	8.1
2-1/2" x 1"	65 x 25	100	48	127	127	3	4	3	-	11.1	11.5
2-1/2" x 1-1/2"	65 x 40	100	65	127	127	3	4	3	-	11.8	12.2
2-1/2" x 2"	65 x 50	100	87	127	127	3	4	3	4	12.6	13.0
3" x 1"	80 x 25	117	48	140	140	3	5	3	-	13.8	14.4
3" x 1-1/2"	80 x 40	117	65	140	140	3	5	3	-	14.0	14.6
3" x 2"	80 x 50	117	48	140	140	3	5	3	4	15.4	16.0
3" x 2-1/2"	80 x 65	117	100	140	140	3	5	3	4	16.8	17.4
4" x 1"	100 x 25	151	48	165	165	3	5	3	-	19.0	19.8
4" x 1.5"	100 x 40	151	65	165	165	3	5	3	-	19.8	20.6
4" x 2"	100 x 50	151	87	165	165	3	5	3	4	21.0	21.8
4" x 2-1/2"	100 x 65	151	100	165	165	3	5	3	4	22.1	22.9
4" x 3"	100 x 80	151	117	165	165	3	5	3	5	23.0	24.0
5" x 2"	125 x 50	173	87	190	190	4	7	3	4	27.5	28.6
5" x 2-1/2"	125 x 65	173	100	190	190	4	7	3	4	28.2	29.2
5" x 3"	125 x 80	173	117	190	190	4	7	3	5	29.0	30.1
5" x 4"	125 x 100	173	151	190	190	4	7	3	5	30.5	31.8
6" x 2"	150 x 50	203	87	203	203	4	7	3	4	32.0	33.1
6" x 2-1/2"	150 x 65	203	100	203	203	4	7	3	4	33.0	34.5
6" x 3"	150 x 80	203	117	203	203	4	7	3	5	35.2	37.0
6" x 4"	150 x 100	203	151	203	203	4	7	3	5	37.0	38.9
8" x 3"	200 x 80	256	117	228	228	4	7.5	3	5	54.5	56.7
8" x 4"	200 x 100	256	151	228	228	4	7.5	3	5	56.0	59.1
8" x 5"	200 x 125	256	173	228	228	4	7.5	3	7	59.2	62.3
8" x 6"	200 x 150	256	203	228	228	4	7.5	4	7	62.5	65.6
10" x 4"	250 x 100	311	151	280	280	5	9	3	5	79.3	82.8
10" x 5"	250 x 125	311	173	280	280	5	9	3	7	83.2	86.9
10" x 6"	250 x 150	311	203	280	280	5	9	4	7	86.5	90.2
10" x 8"	250 x 200	311	256	280	280	5	9	4	7	89.4	93.3
12" x 5"	300 x 125	365	173	305	305	5	11	4	7	126.0	130.5
12" x 6"	300 x 150	365	203	305	305	5	11	4	7	131.0	136.0
12" x 8"	300 x 200	365	256	305	305	5	11	4	7.5	134.0	139.8
12" x 10"	300 x 250	365	311	305	305	5	11	5	9	141.0	147.5
14" x 6"	350 x 150	415	203	356	276	5	11	4	7	161.0	169.5
14" x 8"	350 x 200	415	256	356	276	5	11	4	7.5	170.6	179.1
14" x 10"	350 x 250	415	311	356	276	5	11	5	9	189.8	198.3
14" x 12"	356 x 300	415	365	356	356	5	11	5	11	196.1	205.2
16" x 6"	400 x 150	475	203	381	310	6	11	4	7	209.5	222.5
16" x 8"	400 x 200	475	256	381	310	6	11	5	7.5	217.6	231.6
16" x 10"	400 x 250	475	311	381	310	6	11	5	9	228.2	243.3
16" x 12" ⊙	400 x 300	475	365	381	381	3	-	3	-	218.5	-
16" x 14" ⊙	400 x 350	475	415	381	381	3	-	3	-	228.0	-
18" x 10" ⊙	450 x 250	514	311	420	420	3	-	3	-	227.9	-
18" x 12" ⊙	450 x 300	514	365	420	420	3	-	3	-	239.4	-
18" x 14" ⊙	450 x 350	514	415	420	420	3	-	3	-	250.6	-
18" x 16" ⊙	450 x 400	514	475	420	420	3	-	3	-	262.3	-
20" x 10" ⊙	500 x 250	565	311	457	457	3	-	3	-	289.3	-
20" x 12" ⊙	500 x 300	565	365	457	457	3	-	3	-	301.5	-
20" x 14" ⊙	500 x 350	565	415	457	457	3	-	3	-	311.5	-
20" x 16" ⊙	500 x 400	565	475	457	457	3	-	3	-	325.4	-
20" x 18" ⊙	500 x 450	565	514	457	457	3	-	3	-	336.0	-

* S/W: Standard Wall; H/W: Heavy Wall

PTFE Lined Concentric Reducer

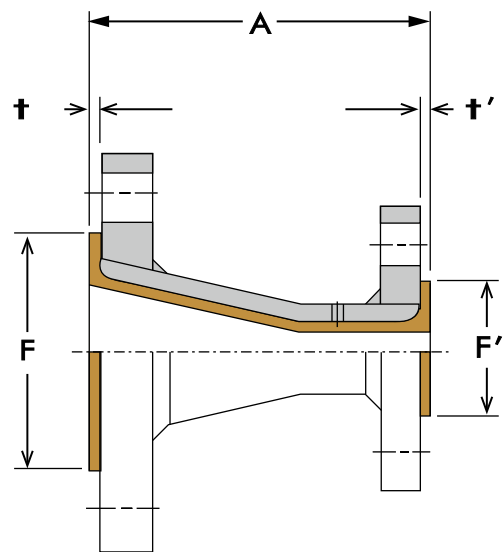
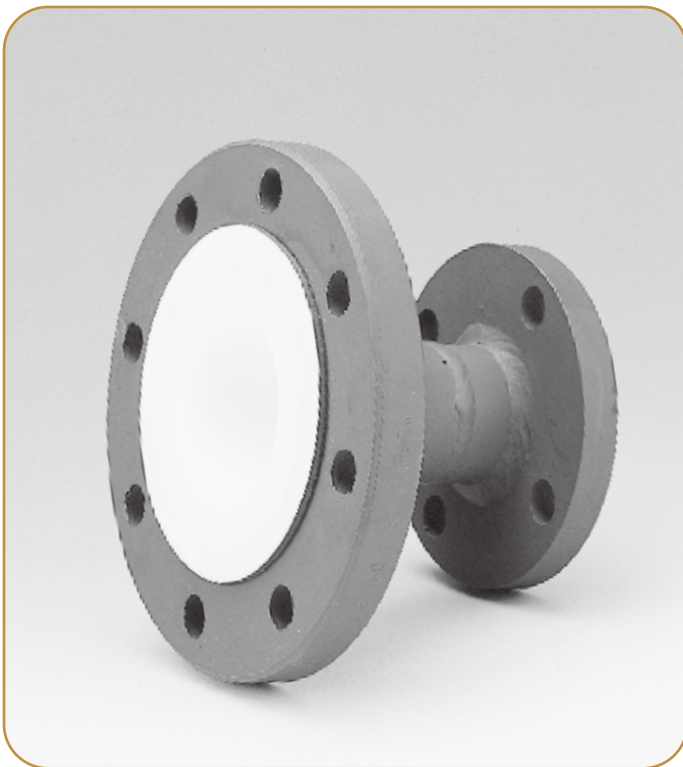

Steel frame: ASTM A234 grade WPB, in compliance with ANSI B16.28

Flange: ASTM A105, in compliance with ANSI B16.5/Class 150lbs; JIS 10K or DIN is also available on request.

Standard: Two fixed flanges; two loose flanges or one loose and one fixed flange are on request.

© : Fabricated by technique of sheet lining.

Lining: Pure PTFE in compliance with ASTM D4894.

Other sizes are available on request.

Flange: ANSI 150 LBS
unit : mm

Nominal size		F	F'	A	t		t'		G.W. (kg)	
Inch	mm				S/W	H/W	S/W	H/W	S/W	H/W
1-1/2" x 1"	40 x 25	65	48	100	3	-	3	-	3.0	-
2" x 1"	50 x 25	87	48	127	3	4	3	-	3.8	3.9
2" x 1-1/2"	50 x 40	87	65	127	3	4	3	-	4.5	4.6
2-1/2" x 1"	65 x 25	100	48	127	3	4	3	-	5.4	5.6
2-1/2" x 1-1/2"	65 x 40	100	65	127	3	4	3	-	6.2	6.4
2-1/2" x 2"	65 x 50	100	87	127	3	4	3	4	7.0	7.3
3" x 1"	80 x 25	117	48	152	3	5	3	-	6.2	6.5
3" x 1-1/2"	80 x 40	117	65	152	3	5	3	-	7.0	7.3
3" x 2"	80 x 50	117	87	152	3	5	3	4	7.6	7.9
3" x 2-1/2"	80 x 65	117	100	152	3	5	3	4	9.0	9.4
4" x 1"	100 x 25	151	48	152	3	5	3	3	8.0	8.3
4" x 1-1/2"	100 x 40	151	65	152	3	5	3	3	8.8	9.1
4" x 2"	100 x 50	151	87	152	3	5	3	4	10.0	10.4
4" x 2-1/2"	100 x 65	151	100	152	3	5	3	4	10.5	10.9
4" x 3"	100 x 80	151	117	152	3	5	3	5	11.8	12.2
5" x 2"	125 x 50	173	87	200	4	7	3	4	14.1	14.6
5" x 2-1/2"	125 x 65	173	100	200	4	7	3	4	14.8	15.3
5" x 3"	125 x 80	173	117	200	4	7	3	5	16.1	16.7
5" x 4"	125 x 100	173	151	200	4	7	3	5	17.7	23.2
6" x 2"	150 x 50	203	87	200	4	7	3	4	14.8	15.4
6" x 2-1/2"	150 x 65	203	100	200	4	7	3	4	15.2	15.8
6" x 3"	150 x 80	203	117	200	4	7	3	5	16.8	17.5
6" x 4"	150 x 100	203	151	200	4	7	3	5	18.6	19.3
8" x 3"	200 x 80	256	117	200	4	7.5	3	5	24.4	25.4
8" x 4"	200 x 100	256	151	200	4	7.5	3	5	25.5	26.7
8" x 5"	200 x 125	256	173	200	4	7.5	3	7	27.2	28.2
8" x 6"	200 x 150	256	203	200	4	7.5	4	7	30.0	31.3
10" x 4"	250 x 100	311	151	250	5	9	3	5	37.8	39.4
10" x 5"	250 x 125	311	173	250	5	9	3	7	38.0	39.5
10" x 6"	250 x 150	311	203	250	5	9	4	7	38.5	39.3
10" x 8"	250 x 200	311	256	250	5	9	4	7.5	39.4	41.3
12" x 5"	300 x 125	365	173	300	5	11	4	7	51.0	54.0
12" x 6"	300 x 150	365	203	300	5	11	4	7	54.0	57.1
12" x 8"	300 x 200	365	256	300	5	11	4	7.5	62.2	65.5
12" x 10"	300 x 250	365	311	300	5	11	5	9	71.8	75.3
14" x 6"	350 x 150	415	203	406	5	11	4	7	96.8	102.3
14" x 8"	350 x 200	415	256	406	5	11	4	7.5	102.3	106.1
14" x 10"	350 x 250	415	311	406	5	11	5	9	109.1	113.2
14" x 12"	356 x 300	415	365	406	5	11	5	11	121.4	125.9
16" x 8"	400 x 200	475	256	457	6	11	5	7.5	131.0	136.0
16" x 10"	400 x 250	475	311	457	6	11	5	9	134.3	139.4
16" x 12"	400 x 300	475	365	457	6	11	5	11	147.8	153.5
16" x 14"	400 x 350	475	415	457	6	11	5	11	159.3	165.4
18" x 10"	450 x 250	514	311	457	3	-	3	-	138.0	-
18" x 12"	450 x 300	514	365	457	3	-	3	-	140.3	-
18" x 14"	450 x 350	514	415	457	3	-	3	-	149.7	-
18" x 16" ☉	450 x 400	514	475	457	3	-	3	-	158.7	-
20" x 12" ☉	500 x 300	565	365	600	3	-	3	-	177.7	-
20" x 14" ☉	500 x 350	565	415	600	3	-	3	-	186.7	-
20" x 16" ☉	500 x 400	565	475	600	3	-	3	-	196.0	-
20" x 18" ☉	500 x 450	565	514	600	3	-	3	-	200.3	-

** S/W: Standard Wall; H/W: Heavy Wall*

PTFE Lined Eccentric Reducer

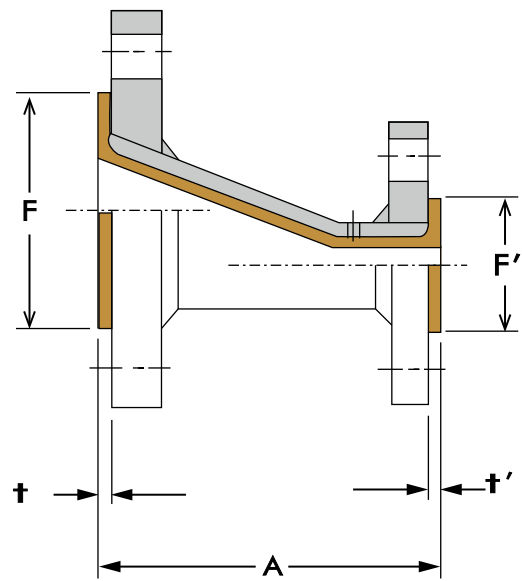
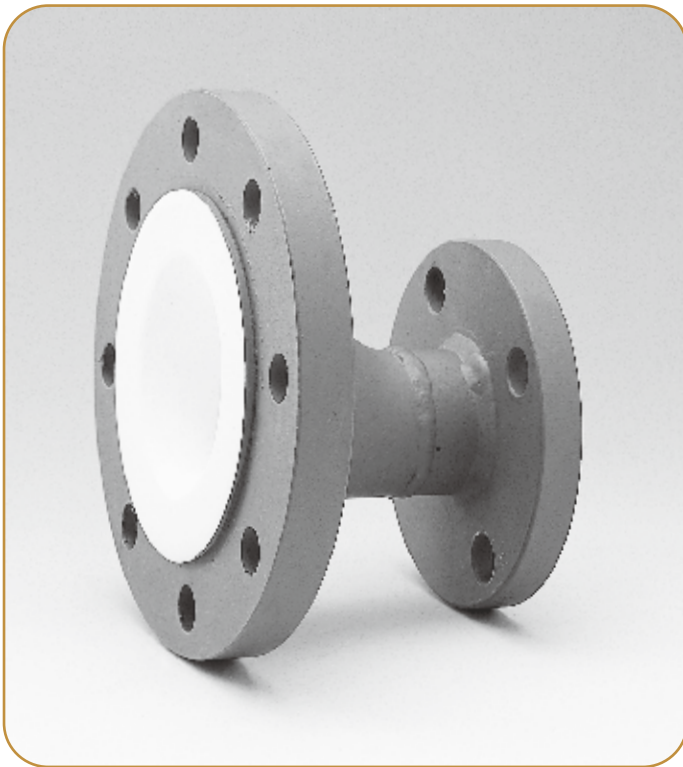

Steel frame: ASTM A234 grade WPB, in compliance with ANSI B16.28

Flange: ASTM A105, in compliance with ANSI B16.5/Class 150lbs; JIS 10K or DIN is also available on request.

Standard: Two fixed flanges; two loose flanges or one loose one fixed flange are on request.

© : Fabricated by technique of sheet lining.

Lining: Pure PTFE in compliance with ASTM D4894.

Other sizes are available on request.

Flange: ANSI 150 LBS

unit : mm

Nominal size		F	F'	A	t		t'		G.W. (kg)	
Inch	mm				S/W	H/W	S/W	H/W	S/W	H/W
1-1/2" x 1"	40 x 25	65	48	100	3	-	3	-	3.0	-
2" x 1"	50 x 25	87	48	127	3	4	3	-	4.0	4.1
2" x 1-1/2"	50 x 40	87	65	127	3	4	3	-	4.3	4.4
2-1/2" x 1"	65 x 25	100	48	127	3	4	3	-	5.4	5.5
2-1/2" x 1-1/2"	65 x 40	100	65	127	3	4	3	-	5.6	5.8
2-1/2" x 2"	65 x 50	100	87	127	3	4	3	4	6.5	6.8
3" x 1"	80 x 25	117	48	152	3	5	3	-	6.8	7.0
3" x 1-1/2"	80 x 40	117	65	152	3	5	3	-	7.2	7.4
3" x 2"	80 x 50	117	87	152	3	5	3	4	7.8	8.1
3" x 2-1/2"	80 x 65	117	100	152	3	5	3	4	9.0	9.3
4" x 1"	100 x 25	151	48	152	3	5	3	3	9.0	9.3
4" x 1-1/2"	100 x 40	151	65	152	3	5	3	3	9.0	9.4
4" x 2"	100 x 50	151	87	152	3	5	3	4	10.0	10.4
4" x 2-1/2"	100 x 65	151	100	152	3	5	3	4	11.5	11.9
4" x 3"	100 x 80	151	117	152	3	5	3	5	12.8	13.2
5" x 2"	125 x 50	173	87	200	4	7	3	4	14.1	14.6
5" x 2-1/2"	125 x 65	173	100	200	4	7	3	4	14.8	15.3
5" x 3"	125 x 80	173	117	200	4	7	3	5	16.1	16.7
5" x 4"	125 x 100	173	151	200	4	7	3	5	17.7	23.2
6" x 2"	150 x 50	203	87	200	4	7	3	4	15.6	16.2
6" x 2-1/2"	150 x 65	203	100	200	4	7	3	4	16.2	16.8
6" x 3"	150 x 80	203	117	200	4	7	3	5	17.0	17.7
6" x 4"	150 x 100	203	151	200	4	7	3	5	18.7	19.4
8" x 3"	200 x 80	256	117	200	4	7.5	3	5	24.4	25.4
8" x 4"	200 x 100	256	151	200	4	7.5	3	5	25.5	26.7
8" x 5"	200 x 125	256	173	200	4	7.5	3	7	27.2	28.2
8" x 6"	200 x 150	256	203	200	4	7.5	4	7	30.0	31.3
10" x 4"	250 x 100	311	151	250	5	9	3	5	42.5	44.1
10" x 5"	250 x 125	311	173	250	5	9	3	7	43.0	44.5
10" x 6"	250 x 150	311	203	250	5	9	4	7	44.6	46.2
10" x 8"	250 x 200	311	256	250	5	9	4	7.5	50.0	51.9
12" x 5"	300 x 125	365	173	300	5	11	4	7	53.0	55.0
12" x 6"	300 x 150	365	203	300	5	11	4	7	55.0	57.1
12" x 8"	300 x 200	365	256	300	5	11	4	7.5	63.2	66.5
12" x 10"	300 x 250	365	311	300	5	11	5	9	73.0	76.5
14" x 6"	350 x 150	415	203	406	5	11	4	7	101.0	104.5
14" x 8"	350 x 200	415	256	406	5	11	4	7.5	105.1	108.9
14" x 10"	350 x 250	415	311	406	5	11	5	9	112.8	116.9
14" x 12"	356 x 300	415	365	406	5	11	5	11	124.4	128.9
16" x 8"	400 x 200	475	256	457	6	11	5	7.5	134.0	139.0
16" x 10"	400 x 250	475	311	457	6	11	5	9	139.2	144.3
16" x 12"	400 x 300	475	365	457	6	11	5	11	151.8	157.5
16" x 14"	400 x 350	475	415	457	6	11	5	11	164.3	170.4
18" x 10"	450 x 250	514	311	457	3	-	3	-	138.0	-
18" x 12" ☉	450 x 300	514	365	457	3	-	3	-	140.3	-
18" x 14" ☉	450 x 350	514	415	457	3	-	3	-	149.7	-
18" x 16" ☉	450 x 400	514	475	457	3	-	3	-	158.7	-
20" x 12" ☉	500 x 300	565	365	600	3	-	3	-	177.7	-
20" x 14" ☉	500 x 350	565	415	600	3	-	3	-	186.7	-
20" x 16" ☉	500 x 400	565	475	600	3	-	3	-	196.0	-
20" x 18" ☉	500 x 450	565	514	600	3	-	3	-	200.3	-

* S/W: Standard Wall; H/W: Heavy Wall

PTFE Lined Cross

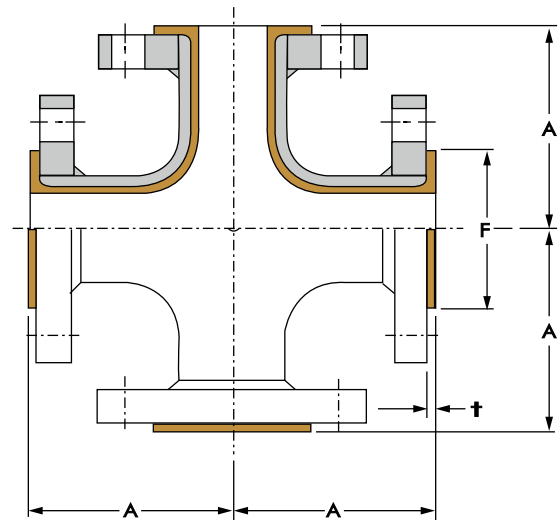

Flange: ANSI 150LBS

unit : mm

Nominal size		F	A	t		G.W. (kg)	
Inch	mm			Standard wall	Heavy wall	Standard wall	Heavy wall
1"	25	48	89	3.0	-	5.0	-
1-1/2"	40	65	102	3.0	-	8.5	-
2"	50	87	114	3.0	4.0	11.8	12.3
3"	80	117	140	3.0	5.0	22.8	23.4
4"	100	151	165	3.0	5.0	31.8	32.6
6"	150	203	203	4.0	7.0	53.0	54.8
8"	200	256	228	4.0	7.5	66.0	68.8

Steel frame: ASTM A234 grade WPB, in compliance with ANSI B16.28

Flange: ASTM A105, in compliance with ANSI B16.5/Class 150lbs; JIS 10K or DIN is also available on request.

Standard: Four fixed flanges; four loose flanges, two loose and two fixed flanges, one fixed and three loose flanges are on request.

Lining: Pure PTFE in compliance with ASTM D4894.

Other sizes are available on request.

PTFE Lined Sight Glass

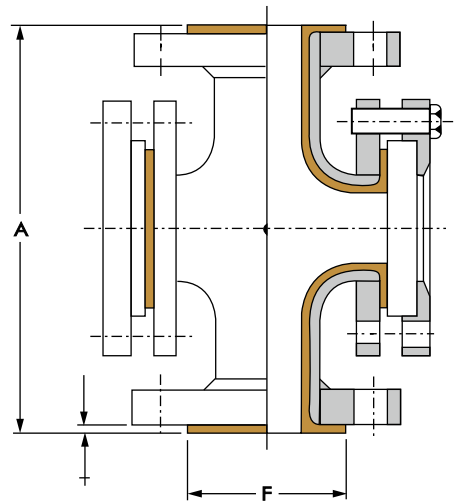

Flange: ANSI 150LBS

unit : mm

Nominal size		F	A	t		G.W. (kg)	
Inch	mm			Standard wall	Heavy wall	Standard wall	Heavy wall
1"	25	48	178	3	-	7.0	-
1-1/2"	40	65	204	3	-	10.2	-
2"	50	87	228	3	4	12.9	13.3
3"	80	117	280	3	5	22.7	23.2
4"	100	151	330	3	5	25.6	26.3
6"	150	203	406	4	7	51.6	53.2
8"	200	256	456	4	7.5	64.5	67.0

Steel frame: ASTM A234 grade WPB, in compliance with ANSI B16.28

Flange: ASTM A105, in compliance with ANSI B16.5/Class 150lbs; JIS 10K or DIN is also available on request.

Standard: Two fixed flanges; two loose flange or one loose and one fixed flange are on request.

Lining: Pure PTFE in compliance with ASTM D4894.

Sight glasses: Press glass with PFA film lined.

Other sizes are available on request.

PTFE Lined Reducing Flange

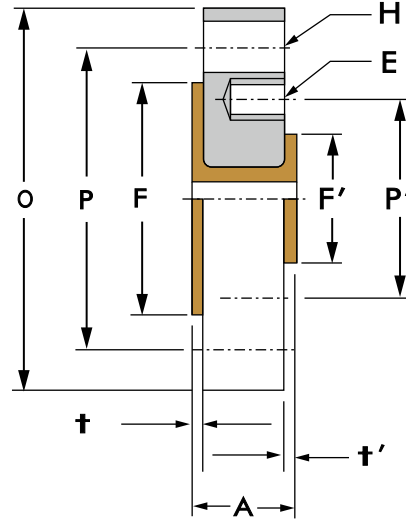
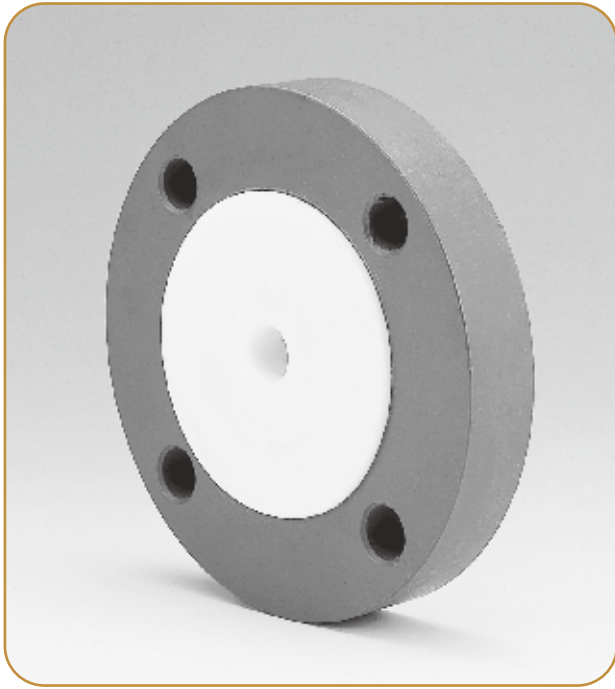

Lining: Pure PTFE in compliance with ASTM D4894.
Other sizes are available on request.

Flange: ANSI 150LBS

unit: mm

Nominal size Inch	A		F	F	t		t'		H holes x Ø	P	P'	O (OD)	E holes x Ø	G.W. (kg)	
	S/W	H/W			S/W	H/W	S/W	H/W						S/W	H/W
1" x 1/2"	38	-	48	32	3	-	3	-	4-TAP x 1/2"	79.4	60.3	108	4-TAP x 1/2"	2.2	-
1" x 3/4"	38	-	48	40	3	-	3	-	4-TAP x 1/2"	79.4	69.0	108	4-TAP x 1/2"	2.2	-
1-1/2" x 3/4"	38	-	65	40	3	-	3	-	4-TAP x 1/2"	98.4	69.0	127	4-TAP x 1/2"	3.1	-
1-1/2" x 1"	38	-	65	48	3	-	3	-	4-TAP x 1/2"	98.4	79.4	127	4-TAP x 1/2"	3.2	-
2" x 1"	38	39	87	48	3	4	3	-	4-TAP x 5/8"	120.6	79.4	152	4-TAP x 1/2"	4.4	4.5
2" x 1-1/2"	38	39	87	65	3	4	3	-	4-TAP x 5/8"	120.6	98.4	152	4-TAP x 1/2"	4.2	4.3
2-1/2" x 1"	38	39	100	48	3	4	3	-	4 x 19 Ø	139.7	79.4	178	4-TAP x 5/8"	6.1	6.3
2-1/2" x 1-1/2"	38	39	100	65	3	4	3	-	4-TAP x 5/8"	139.7	98.4	178	4-TAP x 1/2"	6.0	6.2
2-1/2" x 2"	38	40	100	87	3	4	3	4	4-TAP x 5/8"	139.7	120.6	178	4-TAP x 5/8"	5.6	5.9
3" x 1"	38	40	117	48	3	5	3	-	4 x 19 Ø	152.4	79.4	191	4-TAP x 1/2"	7.0	7.3
3" x 1-1/2"	38	40	117	65	3	5	3	-	4 x 19 Ø	152.4	98.4	191	4-TAP x 1/2"	7.0	7.3
3" x 2"	38	41	117	48	3	5	3	4	4-TAP x 5/8"	152.4	120.6	191	4-TAP x 5/8"	6.8	7.1
3" x 2-1/2"	38	41	117	100	3	5	3	4	4-TAP x 5/8"	152.4	139.7	191	4-TAP x 5/8"	6.5	6.9
4" x 1"	38	40	151	48	3	5	3	-	8 x 19 Ø	190.5	79.4	229	4-TAP x 1/2"	12.5	12.9
4" x 1-1/2"	38	40	151	65	3	5	3	-	8 x 19 Ø	190.5	98.4	229	4-TAP x 1/2"	12.2	12.6
4" x 2"	38	41	151	87	3	5	3	4	8 x 19 Ø	190.5	120.6	229	4-TAP x 5/8"	10.5	11.0
4" x 2-1/2"	38	41	151	100	3	5	3	4	8-TAP x 5/8"	190.5	139.7	229	4-TAP x 5/8"	10.0	10.6
4" x 3"	38	42	151	117	3	5	3	5	8-TAP x 5/8"	190.5	152.4	229	4-TAP x 5/8"	9.8	10.3
5" x 1"	37	40	173	48	4	7	3	-	8 x 23 Ø	215.9	79.4	254	4-TAP x 1/2"	12.8	13.3
5" x 1-1/2"	37	40	173	65	4	7	3	-	8 x 23 Ø	215.9	98.4	254	4-TAP x 1/2"	12.4	12.9
5" x 2"	37	41	173	87	4	7	3	4	8 x 23 Ø	215.9	120.6	254	4-TAP x 5/8"	12.4	13.0
5" x 2-1/2"	37	41	173	100	4	7	4	4	8 x 23 Ø	215.9	139.7	254	4-TAP x 5/8"	12.0	12.6

* S/W: Standard Wall; H/W: Heavy Wall

5" x 3"	37	42	173	117	4	7	3	5	8-TAP x 3/4"	215.9	152.4	254	4-TAP x 5/8"	11.8	12.4
5" x 4"	37	42	173	151	4	7	3	5	8-TAP x 3/4"	215.9	190.5	254	8-TAP x 5/8"	10.8	11.6
6" x 1"	37	40	203	48	4	7	3	-	8 x 23 Ø	241.3	79.4	279	4-TAP x 1/2"	14.2	15.0
6" x 1-1/2"	37	40	203	65	4	7	3	-	8 x 23 Ø	241.3	98.4	279	4-TAP x 1/2"	13.8	14.6
6" x 2"	37	41	203	87	4	7	3	4	8 x 23 Ø	241.3	120.6	279	4-TAP x 5/8"	13.5	14.3
6" x 2-1/2"	37	41	203	100	4	7	3	4	8 x 23 Ø	241.3	139.7	279	4-TAP x 5/8"	13.4	14.3
6" x 3"	37	42	203	117	4	7		5	8 x 23 Ø	241.3	152.4	279	4-TAP x 5/8"	13.2	14.1
6" x 4"	37	42	203	151	4	7	3	5	8-TAP x 3/4"	241.3	190.5	279	8-TAP x 5/8"	12.6	13.6
8" x 1"	37	40.5	256	48	4	7	3	-	8 x 23 Ø	298.4	79.4	343	4-TAP x 1/2"	22.5	23.5
8" x 1-1/2"	37	40.5	256	65	4	7	3	-	8 x 23 Ø	298.4	98.4	343	4-TAP x 1/2"	22.0	23.0
8" x 2"	37	41.5	256	87	4	7	3	4	8 x 23 Ø	298.4	120.6	343	4-TAP x 5/8"	21.6	22.6
8" x 3"	37	42.5	256	117	4	7	3	5	8 x 23 Ø	298.4	152.4	343	4-TAP x 5/8"	21.0	22.0
8" x 4"	37	42.5	256	151	4	7	3	5	8 x 23 Ø	298.4	190.5	343	8-TAP x 5/8"	20.0	21.2
8" x 5"	37	44.5	256	173	4	7	3	7	8 x 23 Ø	298.4	215.9	343	8-TAP x 3/4"	19.2	20.4
8" x 6"	38	44.5	256	203	4	7	4	7	8-TAP x 3/4"	298.4	241.3	343	8-TAP x 3/4"	18.8	20.0
10" x 1"	38	42	311	48	5	9	3	-	12 x 25 Ø	361.9	79.4	406	4-TAP x 1/2"	34.7	36.0
10" x 1-1/2"	38	42	311	65	5	9	3	-	12 x 25 Ø	361.9	98.4	406	4-TAP x 1/2"	34.5	35.8
10" x 2"	38	43	311	87	5	9	3	4	12 x 25 Ø	361.9	120.6	406	4-TAP x 5/8"	34.2	35.5
10" x 3"	38	44	311	117	5	9	3	5	12 x 25 Ø	361.9	152.4	406	4-TAP x 5/8"	33.5	34.8
10" x 4"	38	44	311	151	5	9	3	5	12 x 25 Ø	361.9	190.5	406	8-TAP x 5/8"	32.5	33.8
10" x 5"	38	46	311	173	5	9	3	7	12 x 25 Ø	361.9	215.9	406	8-TAP x 3/4"	31.2	32.5
10" x 6"	39	46	311	203	5	9	4	7	12 x 25 Ø	361.9	241.3	406	8-TAP x 3/4"	30.0	31.3
10" x 8"	39	46.5	311	256	5	9	4	7	12-TAP x 7/8"	361.9	298.4	406	8-TAP x 3/4"	26.0	27.5
12" x 2"	38	44.5	365	173	5	10	3	4	12 x 25 Ø	431.8	120.6	483	4-TAP x 5/8"	48.0	49.5
12" x 3"	38	45.5	365	203	5	10	3	5	12 x 25 Ø	431.8	152.4	483	4-TAP x 5/8"	47.6	49.1
12" x 4"	38	45.5	365	256	5	10	3	5	12 x 25 Ø	431.8	190.5	483	8-TAP x 5/8"	47.4	48.9
12" x 5"	38	47.5	365	173	5	10	3	7	12 x 25 Ø	431.8	215.9	483	8-TAP x 3/4"	46.0	47.5
12" x 6"	39	47.5	365	203	5	10	4	7	12 x 25 Ø	431.8	241.3	483	8-TAP x 3/4"	44.8	46.3
12" x 8"	39	48	365	256	5	10	4	7	12 x 25 Ø	431.8	298.4	483	8-TAP x 3/4"	40.8	42.3
12" x 10"	40	49.5	365	311	5	10	5	9	12-TAP x 7/8"	431.8	361.9	483	12-TAP x 7/8"	36.2	37.7
14" x 6"	39	48	415	203	5	11	4	7	12 x 29 Ø	476.2	241.3	533	8-TAP x 3/4"	66.5	68.5
14" x 8"	39	48.5	415	256	5	11	4	7.5	12 x 29 Ø	476.2	298.4	533	8-TAP x 3/4"	64.1	66.1
14" x 10"	40	50	415	311	5	11	5	9	12 x 29 Ø	476.2	361.9	533	12-TAP x 7/8"	59.1	61.1
14" x 12"	40	51.5	415	365	5	11	5	11	12-TAP x 1"	476.2	431.8	533	12-TAP x 7/8"	53	55
16" x 6"	40	48	475	203	6	11	4	7	16 x 29 Ø	539.5	241.3	597	8-TAP x 3/4"	88.6	91.1
16" x 8"	41	48.5	475	256	6	11	5	7.5	16 x 29 Ø	539.5	298.4	597	8-TAP x 3/4"	85.8	88.3
16" x 10"	41	50	475	311	6	11	5	9	16 x 29 Ø	539.5	361.9	597	12-TAP x 7/8"	81.1	83.6
16" x 12"	41	51.5	475	365	6	11	5	11	16 x 29 Ø	539.5	431.8	597	12-TAP x 7/8"	75.2	77.7
16" x 14"	41	52	475	415	6	11	5	11	16-TAP x 1"	539.5	476.2	597	12-TAP x 1"	68.6	71.1
18" x 10"	36	-	514	311	3	-	3	-	16 x 32 Ø	577.8	361.9	635	12-TAP x 7/8"	66.5	-
18" x 12"	36	-	514	365	3	-	3	-	16 x 32 Ø	577.8	431.8	635	12-TAP x 7/8"	59.7	-
18" x 14"	36	-	514	415	3	-	3	-	16-TAP x 1-1/8"	577.8	476.2	635	12-TAP x 1"	53.5	-
18" x 16"	36	-	514	475	3	-	3	-	16-TAP x 1-1/8"	577.8	539.5	635	16-TAP x 1"	46.7	-
20" x 10"	36	-	565	311	3	-	3	-	20 x 32 Ø	635	361.9	700	12-TAP x 7/8"	83	-
20" x 12"	36	-	565	365	3	-	3	-	20 x 32 Ø	635	431.8	700	12-TAP x 7/8"	75	-
20" x 14"	36	-	565	415	3	-	3	-	20 x 32 Ø	635	476.2	700	12-TAP x 1"	68.8	-
20" x 16"	36	-	565	475	3	-	3	-	20-TAP x 1-1/8"	635	539.5	700	16-TAP x 1"	62	-
20" x 18"	36	-	565	514	3	-	3	-	20-TAP x 1-1/8"	635	577.8	700	16-TAP x 1-1/8"	54.1	-

*S/W: Standard Wall; H/W: Heavy Wall

PTFE Lined Instrument Tee

Flange: ANSI 150LBS

unit: mm

Nominal size		F	F'	A	P	t	t'	G.W. (kg)
Inch	mm							
1" x 1"	25 x 25	48	48	56	90	3	3	2.4
1-1/2" x 1"	40 x 25	65	48	56	100	3	3	3.0
1-1/2" x 1-1/2"	40 x 40	65	65	66	100	3	3	3.9
2" x 1"	50 x 25	87	48	56	114	3	3	3.2
2" x 1-1/2"	50 x 40	87	65	66	114	3	3	4.8
2" x 2"	50 x 50	87	87	77	114	3	3	6.3
2-1/2" x 1"	65 x 25	100	48	56	127	3	3	4.4
2-1/2" x 1-1/2"	65 x 40	100	65	66	127	3	4	6.0
2-1/2" x 2"	65 x 50	100	87	77	127	3	3	7.7
3" x 1"	80 x 25	117	48	56	140	3	3	4.8
3" x 1-1/2"	80 x 40	117	65	66	140	3	3	6.4
3" x 2"	80 x 50	117	87	77	140	3	3	8.2
4" x 1"	100 x 25	151	48	56	165	3	3	7.2
4" x 1-1/2"	100 x 40	151	65	66	165	3	3	9.6
4" x 2"	100 x 50	151	87	77	165	3	3	12.0
5" x 1"	125 x 25	175	48	58	180	4	3	7.8
5" x 1-1/2"	125 x 40	175	65	68	180	4	3	9.1
5" x 2"	125 x 50	175	87	78	180	4	3	10.5
6" x 1"	150 x 25	203	48	58	200	4	3	9.8
6" x 1-1/2"	150 x 40	203	65	68	200	4	3	12.3
6" x 2"	150 x 50	203	87	79	200	4	3	15.2
8" x 1"	200 x 25	256	48	58	228	4	3	13.2
8" x 1-1/2"	200 x 40	256	65	68	228	4	3	16.3
8" x 2"	200 x 50	256	87	79	228	4	3	19.9
10" x 1"	250 x 25	311	48	60	250	5	3	18.6
10" x 1-1/2"	250 x 40	311	65	70	250	5	3	22.7
10" x 2"	250 x 50	311	87	81	250	5	3	27.4
12" x 1"	300 x 25	365	48	60	305	5	3	26.5
12" x 1-1/2"	300 x 40	365	65	70	305	5	3	32.3
12" x 2"	300 x 50	365	87	81	305	5	3	38.7
14" x 1"	350 x 25	415	48	60	318	5	3	27.9
14" x 1-1/2"	350 x 40	415	65	70	318	5	3	33.8
14" x 2"	350 x 50	415	87	81	318	5	3	40.5
16" x 1"	350 x 25	475	48	62	350	6	3	40.5
16" x 1-1/2"	350 x 40	475	65	72	350	6	3	46.5
16" x 2"	350 x 50	475	87	83	350	6	3	53.7
18" x 1" ⊙	350 x 25	514	48	60	381	3	3	30.6
18" x 1-1/2" ⊙	350 x 40	514	65	70	381	3	3	36.4
18" x 2" ⊙	350 x 50	514	87	81	381	3	3	43.1
20" x 1" ⊙	350 x 25	565	48	60	406	3	3	40.5
20" x 1-1/2" ⊙	350 x 40	565	65	70	406	3	3	48.4
20" x 2" ⊙	350 x 50	565	87	81	406	3	3	58.0

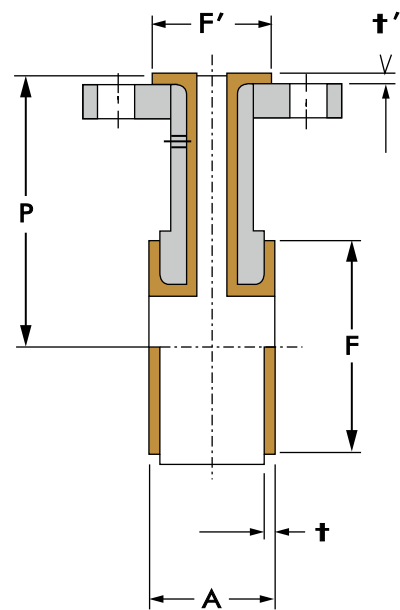
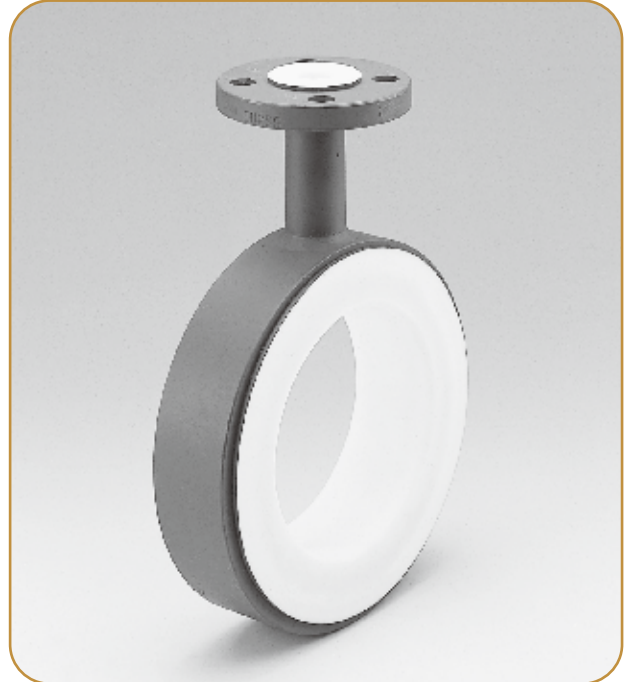

Steel frame: ASTM A234 grade WPB, in compliance with ANSI B16.28

Flange: ASTM A105, in compliance with ANSI B16.5/Class 150lbs; JIS 10K or DIN is also available on request.

Standard: One fixed flange; one loose flange is on request.

⊙ : fabricated by technique of sheet lining.

Lining: Pure PTFE in compliance with ASTM D4894.

Other sizes are available on request.

Y-TEE

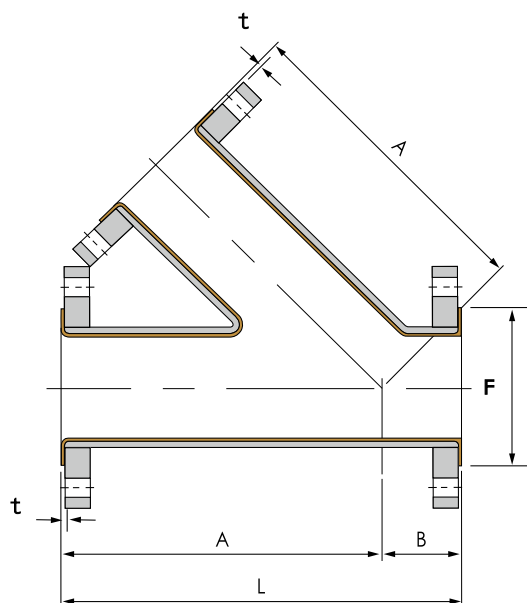

Flange: ANSI 150LBS

unit : mm

Nominal size		F	A	B	L	t		G.W. (kg)	
Inch	mm					Standard wall	Heavy wall	Standard wall	Heavy wall
2"	50	87	203	64	267	3.0	-	10.5	-
3"	80	117	254	76	330	3.0	-	21.4	-
4"	100	151	305	76	381	3.0	5.0	31.2	32.4
6"	150	203	368	89	457	4.0	7.0	55.0	57.5
8"	200	256	445	115	560	4.0	7.5	75.5	79.8

- a. 2", 3"(3mm), lining material is ETFE or PFA
- b. 4",6",8"(4mm), lining material is PTFE

Flange: ASTM A105, in compliance with ANSI B16.5/Class 150lbs; JIS 10K or DIN is also available on request.

Bellows

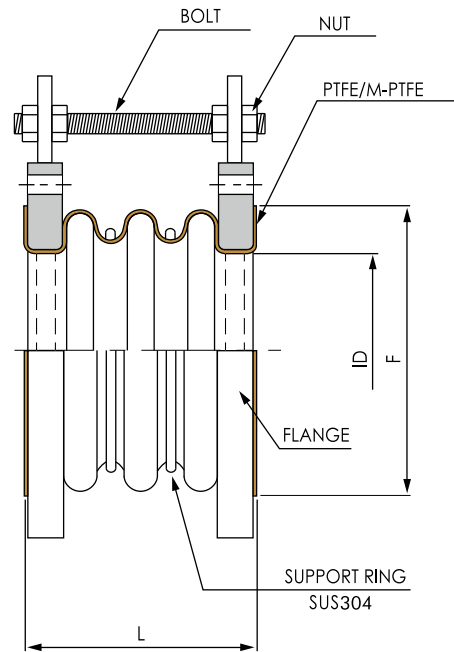
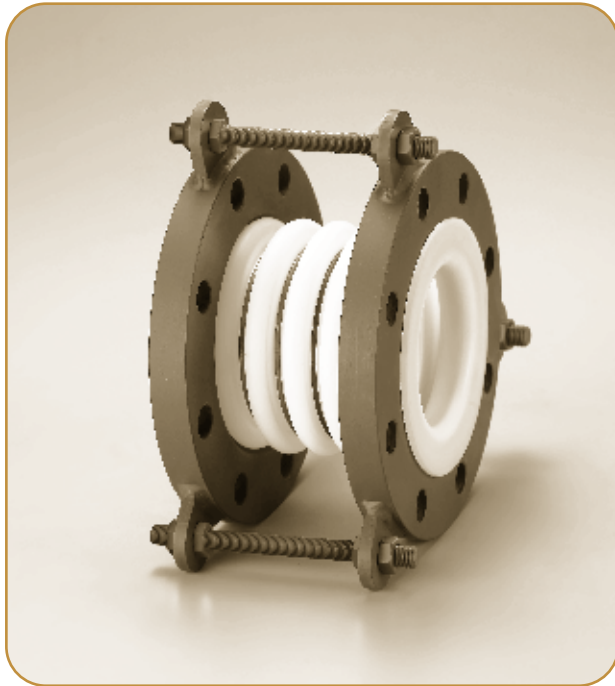

Flange: ANSI 150LBS

unit : mm

Nominal size		L		t	ID	F	Pressure Resistance Kg/cm ² G					
							25°C		115°C		200°C	
Inch	mm	3 con.	5 con.				3 con.	5 con.	3 con.	5 con.	3 con.	5 con.
1"	25	61	83	3	24	48	8	5	3	2	1.5	1
1-1/2"	40	76	105	3	38	68	8	5	3	2	1.5	1
2"	50	78	110	3	50	87	8	5	3	2	1.5	1
2-1/2"	65	86	110	3	60	100	6	5	2	1.5	1.5	1
3"	80	95	120	3	77	117	5	4	2	1.5	1.5	1
4"	100	96	120	3	95	151	5	4	2	1.5	1.5	1
6"	150	112	150	4	150	203	5	4	1.5	1	1	0.5
8"	200	123	155	4	195	256	3	2	1.5	1	1	0.5
10"	250	128	160	5	245	311	3	2	1.5	1	1	0.5
12"	300	133	165	5	295	365	2	1	1	0.5	0.5	-
14"	350	134	170	5	330	415	1	0.5	0.5	-	-	-

- (a) Flange cannot be assembled and installed after forming 2 convolution, so it cannot produce.
- (b) The list data is recommended for highest working pressure.

High Pressure Bellows

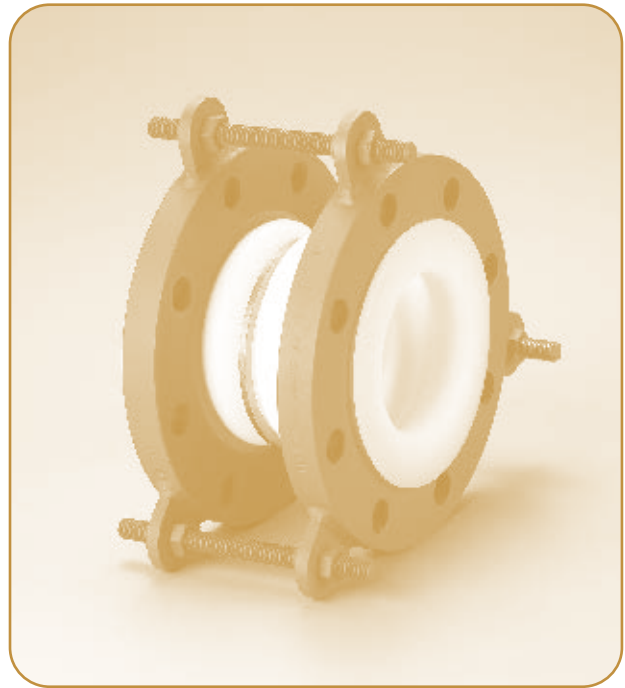
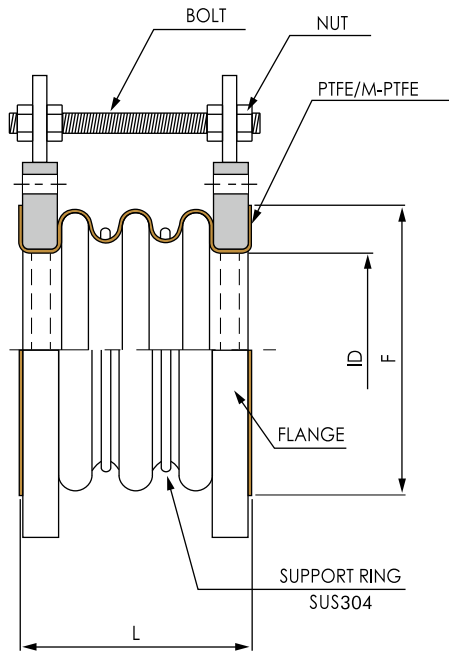

Flange: ANSI 150LBS

unit : mm

Nominal size		L			t	ID	F	Pressure Resistance Kg/cm ² G								
								25°C			115°C			200°C		
Inch	mm	2 con.	3 con.	5 con.				2 con.	3 con.	5 con.	2 con.	3 con.	5 con.	2 con.	3 con.	5 con.
1"	25	61	80	110	3	22	48	14	12	9	11	9	7	6	5	4
1-1/2"	40	61	90	120	3	34	68	14	12	9	11	9	7	6	5	4
2"	50	70	100	150	3	49	87	14	12	9	11	9	7	6	5	4
2-1/2"	65	90	110	150	3	60	100	13	11	8	10	8	6	5	4	3
3"	80	100	125	170	3	74	117	13	11	8	10	8	6	5	4	3
4"	100	100	125	175	3	94	151	13	11	8	10	8	6	5	4	3
5"	125	110	135	175	3	121	175	11	9	7	8	6	4	4	3	2
6"	150	125	150	200	4	144	203	11	9	7	8	6	4	4	3	2
8"	200	125	155	205	5	190	256	11	9	7	8	6	4	4	3	2
10"	250	130	160	210	5	240	311	11	9	7	8	6	4	4	3	2
12"	300	135	165	225	5	290	365	9	7	6	7	5	4	4	3	2
14"	350	140	170	235	5	330	415	7	6	4	5	4	2	3	2	1
16"	400	150	190	270	6	370	475	7	6	4	5	4	2	3	2	1
18"	450	150	190	270	6	425	515	5	4	3	4	3	2	2	1.5	1
20"	500	160	200	280	6	473	565	3	2	1.5	2	1.5	1	1	0.75	0.5
24"	600	170	210	290	6	576	650	3	2	1.5	2	1.5	1	1	0.75	0.5

(a) The list data is recommended for highest working pressure.

Vacuum Resistant Bellows

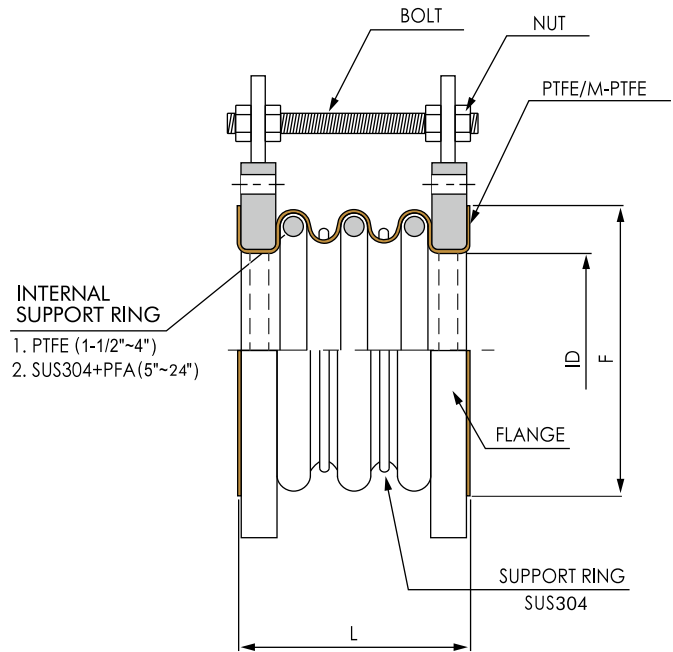
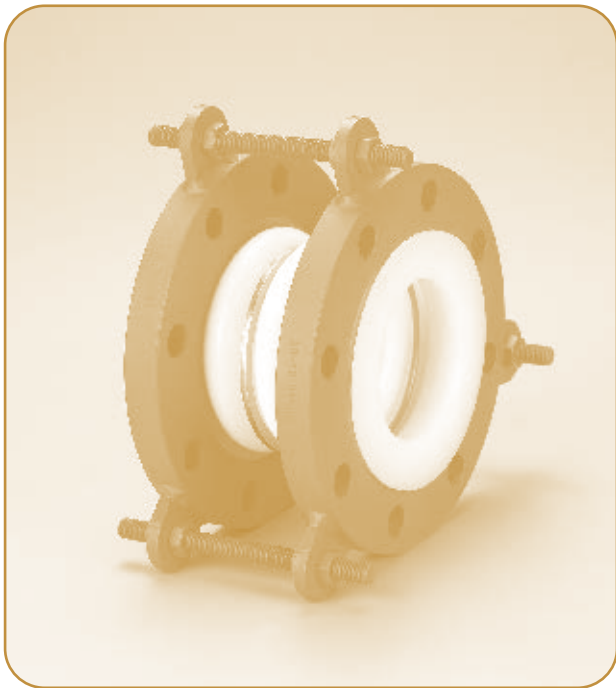

Flange: ANSI 150LBS

unit : mm

Nominal size		L			t	ID	F
Inch	mm	2 con.	3 con.	5 con.			
1-1/2"	40	61	90	105	3	38	68
2"	50	70	100	150	3	50	87
2-1/2"	65	90	110	150	3	63	100
3"	80	100	125	175	3	77	117
4"	100	100	125	175	3	101	151
5"	125	100	135	180	3	121	175
6"	150	125	150	200	4	150	203
8"	200	125	150	205	4	195	256
10"	250	130	160	210	5	245	311
12"	300	135	165	225	5	295	365
14"	350	140	170	235	5	330	415
16"	400	150	195	270	6	378	475
18"	450	160	200	280	6	425	515
20"	500	165	210	290	6	473	565
24"	600	170	220	300	6	576	650

(a) 1" is not able to fabricate.

(b) 1-1/2"~4" internal support ring with PTFE material.

(c) 5"~24" internal support ring with SUS304+PFA material.

Reinforced Bellows

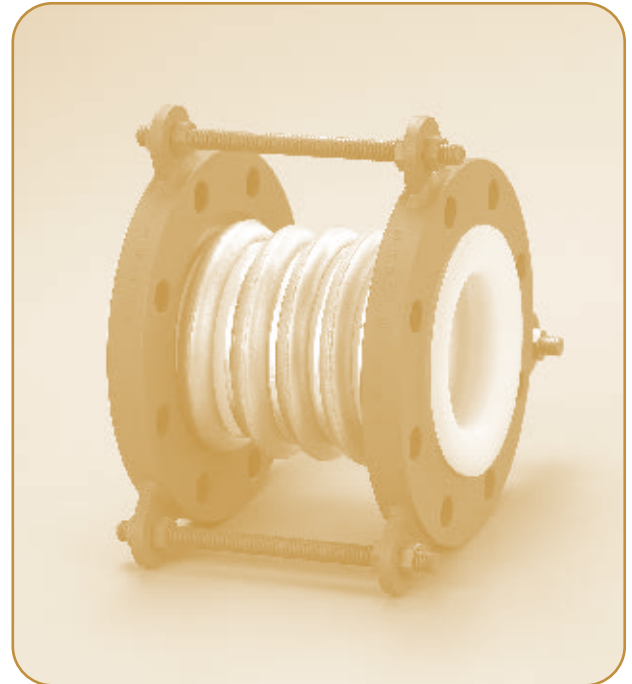
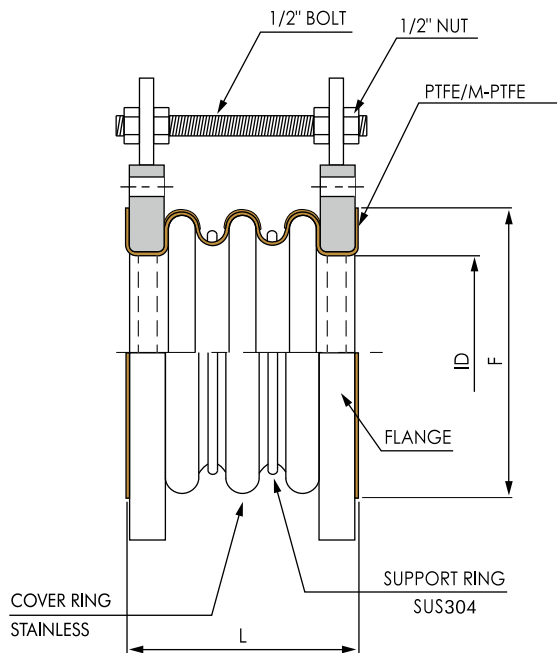

Flange: ANSI 150LBS

Nominal		L			t	ID	F	Pressure Resistance Kg/cm ² G								
								25°C			115°C			200°C		
Inch	mm	2 con.	3 con.	5 con.				2 con.	3 con.	5 con.	2 con.	3 con.	5 con.	2 con.	3 con.	5 con.
2"	50	80	100	150	3	50	87	15	15	15	13	13	13	11	11	11
3"	80	100	125	175	3	77	117	15	15	15	13	13	13	11	11	11
4"	100	100	125	175	3	101	151	15	15	15	13	13	13	11	11	11
6"	150	125	150	200	4	150	203	15	15	15	13	13	13	11	11	11
8"	200	125	150	205	4	195	256	15	15	15	13	13	13	11	11	11
10"	250	130	160	210	5	245	311	15	15	15	13	13	13	11	11	11
12"	300	135	165	230	5	295	365	15	15	15	13	13	13	11	11	11
14"	350	140	170	235	5	330	415	15	15	15	13	13	13	11	11	11
16"	400	150	195	270	6	378	475	15	15	15	13	13	13	11	11	11
18"	450	160	200	275	6	425	515	15	15	15	13	13	13	11	11	11
20"	500	160	210	290	6	473	565	15	15	15	13	13	13	11	11	11
24"	600	170	220	300	6	576	650	15	15	15	13	13	13	11	11	11

(a) Size 1", 1-1/2" are too small, it cannot be produced.

(b) Size 2-1/2", 5" have less request quantity and do not have molding, so it cannot be supplied.

(c) The list data is recommended for highest working pressure.

Solid Spacer

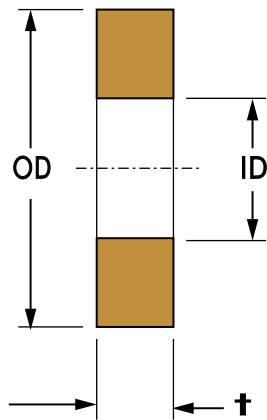

unit : mm

Nominal size		OD	ID	t
Inch	mm			
1/2"	15	50.0	15.0	3~50
3/4"	20	55.0	20.5	3~50
1"	25	66.0	21.5	3~50
1-1/2"	40	85.0	35.5	3~50
2"	50	104.0	47.0	3~50
3"	80	136.0	72.5	3~50
4"	100	174.0	96.5	3~50
6"	150	221.5	145.0	3~50
8"	200	278.5	193.0	3~50
10"	250	330.0	250.0	3~50
12"	300	400.0	300.0	3~50
14"	350	430.0	350.0	3~50
16"	400	490.0	400.0	3~50
18"	450	520.0	450.0	3~50
20"	500	580.0	500.0	3~50
Tolerance		+0, -3	+0, -3	

Material : Pure PTFE in compliance with ASTM D4894.

Other nominal sizes are available on request.

Armored Spacer

unit : mm

Nominal size		OD	ID	t	L(Max.)
Inch	mm				
1/2"	15	35.0	32.0	3	30~75
3/4"	20	43.0	40.0	3	30~75
1"	25	60.0	48.0	3	30~75
1-1/2"	40	76.3	68.0	3	30~75
2"	50	97.9	87.0	3	30~75
3"	80	127.0	117.0	3	30~75
4"	100	168.9	151.0	3	30~75
6"	150	214.3	203.0	4	50~100
8"	200	273.9	256.0	5.5	50~100
10"	250	331.9	311.0	6	50~100
12"	300	404.9	365.0	6	50~100
14"	350	433.2	415.0	6.5	50~100
16"	400	492.0	475.0	7	50~100
18"	450	528.0	514.0	3	50~100
20"	500	590.0	565.0	3	50~100

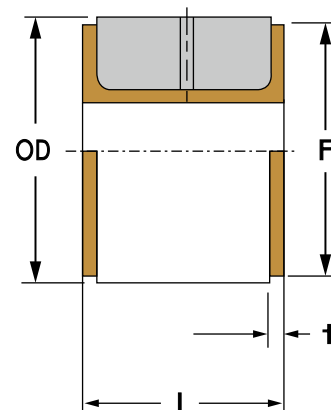

Steel frame: ASTM A53 grade B, in compliance with ANSI B36. 10.

Lining: Pure PTFE in compliance with ASTM D4894.

Other sizes are available on request.

Distance Spacer

unit : mm

Nominal size		OD	F	t	L(Max.)
Inch	mm				
1/2"	15	35.0	32.0	3.0	50~300
3/4"	20	43.0	40.0	3.0	50~300
1"	25	60.0	48.0	3.0	50~300
1-1/2"	40	76.3	68.0	3.0	50~300
2"	50	97.9	87.0	3.0	50~300
3"	80	127.0	117.0	3.0	60~300
4"	100	168.9	151.0	3.0	60~300
6"	150	214.3	203.0	4.0	60~300
8"	200	273.9	256.0	5.5	70~300
10"	250	331.9	311.0	6.0	80~300
12"	300	404.9	365.0	6.0	80~300
14"	350	433.2	415.0	6.5	80~300
16"	400	492.0	475.0	7.0	80~300
18"	450	528.0	514.0	3.0	90~100
20"	500	590.0	565.0	3.0	90~100

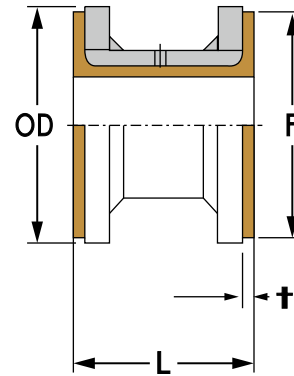

Steel frame: ASTM A53 grade B, in compliance with ANSI B36. 10

Lining: Pure PTFE in compliance with ASTM D4894.

Other sizes are available on request.

PTFE Lined Blind Flange

unit : mm

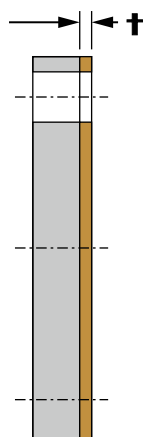

Nominal size		t	G.W. (kg)
Inch	mm		
1/2"	15	3	0.7
3/4"	20	3	0.9
1"	25	3	1.0
1-1/2"	40	3	1.9
2"	50	3	2.5
2-1/2"	65	3	3.4
3"	80	3	4.3
4"	100	3	8.0
6"	150	3	12.5
8"	200	3	21.5
10"	250	3	33.0
12"	300	3	52.0
14"	350	3	66.5
16"	400	3	85.0
18"	450	3	102.8
20"	500	3	133.4

Flange: ASTM A105, in compliance with ANSI B16.5/Class 150lbs; JIS 10K or DIN is also available on request.

Material : Pure PTFE in compliance with ASTM D4894.

Other sizes are available on request.

Pipe Dimensions

(mm)

Diameter		OD	Nominal wall thickness			
Inch	mm		SCH 20	SCH 30	SCH 40	SCH 80
1/2"	15	21.3			2.77	3.73
3/4"	20	26.7			2.87	3.91
1"	25	33.4			3.38	4.55
1-1/2"	40	48.3			3.68	5.08
2"	50	60.3			3.91	5.54
2-1/2"	65	73.0			5.16	7.01
3"	80	88.9			5.49	7.62
4"	100	114.3			6.02	8.56
5"	125	141.3			6.55	9.53
6"	150	168.3			7.11	10.97
8"	200	219.1	6.35	7.04	8.18	12.7
10"	250	273.0	6.35	7.80	9.27	15.09
12"	300	323.8	6.35	8.38	10.31	17.48
14"	350	355.6	7.92	9.53	11.10	19.05
16"	400	406.4	7.92	9.53	12.70	21.44
18"	450	457.2	7.92	11.13	14.27	23.83
20"	500	508.8	9.53	12.70	15.09	26.19

ANSI Class 150lbs Flange Dimensions

(mm)

Nominal size	Flange Diameter	T	Diameter Bolt Circle	Number Bolt Holes	Diameter Bolt Holes
1/2"	89	11.50	60.30	4	16
3/4"	98	13.00	69.80	4	16
1"	108	14.50	79.40	4	16
1-1/2"	127	17.50	98.40	4	16
2"	152	19.50	120.60	4	20
2-1/2"	178	22.50	139.70	4	20
3"	191	24.00	152.40	4	20
4"	229	24.00	190.50	8	20
5"	254	24.00	215.90	8	23
6"	279	25.50	241.30	8	23
8"	343	29.00	298.40	8	23
10"	406	30.50	361.90	12	26
12"	483	32.00	431.80	12	26
14"	533	35.00	476.20	12	29
16"	597	37.00	539.70	16	29
18"	635	40.00	577.80	16	32
20"	699	43.00	635.00	20	32

JIS Class 10K Flange Dimensions

(mm)

Nominal Size (A)	Flange Diameter	T	Diameter Bolt Circle	Number Bolt Holes	Diameter Bolt Holes
15	95	12	70	4	15
20	100	14	75	4	15
25	125	14	90	4	19
40	140	16	105	4	19
50	155	16	120	4	19
65	175	18	140	4	19
80	185	18	150	8	19
100	210	18	175	8	19
125	250	20	210	8	23
150	280	22	240	8	23
200	330	22	290	12	23
250	400	24	355	12	25
300	445	24	400	16	25
350	490	26	445	16	25
400	560	28	510	16	27
450	620	30	565	20	27
500	675	30	620	20	27

DIN PN16 Flange Dimensions

(mm)

Nominal Size (DN)	Flange Diameter	T	Diameter Bolt Circle	Number Bolt Holes	Diameter Bolt Holes
15	95	14	65	4	14
20	105	16	75	4	14
25	115	16	85	4	14
40	150	16	110	4	18
50	165	16	120	4	18
65	185	18	145	4	18
80	200	20	160	8	18
100	220	20	180	8	18
125	250	22	210	8	18
150	285	22	240	8	23
200	340	24	295	12	23
250	405	26	355	12	27
300	460	28	410	12	27
350	520	30	470	16	27
400	580	32	525	16	30
500	715	34	650	20	33

管線組合安裝時

注意要點

1. 尚未準備與配管連接前，不可隨意移開法蘭保護木板以免因溫差或異物造成法蘭面損壞或扭曲。
如果因檢驗而必需開啟法蘭面，也應在檢驗完成後立即將木板蓋上。
2. PTFE 內襯管件之連接並不需要使用墊片，但與異種材質之法蘭面連接時，如金屬、玻璃、陶瓷及FRP塑鋼等，則須使用墊片以保護法蘭面。
3. 螺絲應以適當的力矩鎖緊，力矩值請參考下表。
4. 螺牙需乾淨且潤滑，同時需使用墊圈以確保正確之轉矩。此外，螺絲必須依序均勻地鎖緊。順序如下圖。
5. 如果法蘭面發生洩漏但洩漏一方之螺絲已被適當地鎖緊，則勿再逼緊螺絲，以免造成法蘭面永久的傷害。
正確的方法是，將對角線的螺絲同時放鬆半圈，然後再將洩漏一方之螺絲施以相同之力矩鎖緊。如果洩漏的情況持續，應將所有螺絲鬆開，檢查整個法蘭面是否因刮痕或凹陷而造成洩漏。所有的刮痕或凹陷若未超過整個內襯厚度的20%，則可以利用細砂紙或細砂布將法蘭面磨平再重新安裝。
6. 如果系統在高溫使用下發生洩漏，則應降溫到常溫狀態後，再施以檢查或維修。
7. PTFE 內襯管請勿在靠近鐵件的地方做焊接或乙炔切割以免造成 PTFE 內襯管之永久性的損壞，除非事前已做好適當之預防措施避免過熱的情況發生。
8. 安全排氣孔不可被油漆或水泥等物質阻塞，這些排氣孔是用來釋放可能在高溫中產生並殘留於內襯與鐵件之間之氣體。如果這些氣體沒有被釋放出來，則可能造成PTFE內襯管坍塌的情況；在洩漏到達危險比率之前，排氣孔內直徑之變化同時也提供使用中之內襯管遭到任何意外損壞前之警示作用。

表：鎖緊扭矩

Unit : kgf-m

圖：鎖緊順序

ANSI 150 LBS			JIS 10K		
NPS	MIN.	MAX.	NPS	MIN.	MAX.
1/2"	0.7	0.9	15mm	0.6	0.9
3/4"	0.9	1.3	20mm	0.8	1.2
1"	1.2	1.8	25mm	1.2	1.8
1-1/2"	1.9	2.9	40mm	1.9	2.9
2"	2.9	3.9	50mm	3.1	4.1
3"	3.3	5.4	80mm	3.6	5.6
4"	4.1	6.3	100mm	4.3	6.5
6"	8.0	12.2	150mm	8.4	12.6
8"	8.8	13.4	200mm	9.2	13.8
10"	10.6	15.2	250mm	10.2	14.8
12"	11.6	17.6	300mm	11.1	17.2
14"	14.6	19.8	350mm	13.6	18.8
16"	16.6	22.2	400mm	15.2	20.8
18"	18.6	24.4	450mm	17.2	22.8
20"	19.6	26.6	500mm	18.8	24.6

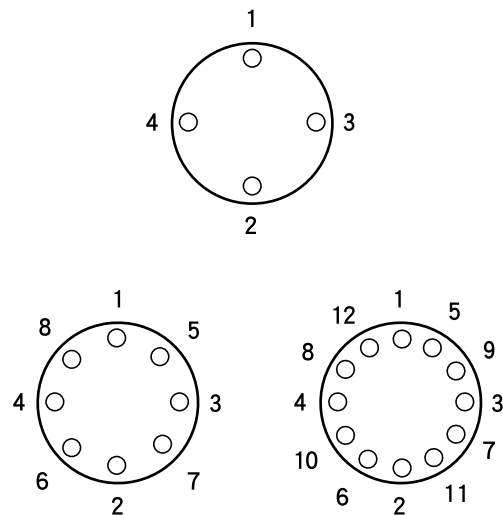

INSTRUCTIONS FOR ASSEMBLING PIPES AND FITTINGS

1. Flange covers should not be removed until flanges are ready to be bolted into position or sealing faces may become damages or distorted. If covers are removed for inspection, they should be replaced immediately.
2. Gaskets are not required with PTFE lined piping components except where they are connected to a flange face of another material such as metal, glass, ceramic, reinforced plastic, etc.
3. Bolts should be tightened using proper bolt torque, the torque values in the tables as below.
4. Threads must be clean and well lubricated. And washers should be used to ensure correct torque.
Bolt should be tightened alternately and evenly, following the sequence shown in the charts.
5. If a flange leak occurs and the bolts of the leaking side have been properly tightened, they should not be tightened further or permanent damage to the sealing face may result. Instead, the bolts on the opposite side should be loosened a half turn at a time and then the bolts on the leaking side should be tightened by the same amount. If the leak persists, the bolts should be removed and the sealing faces should be examined for scratches or dents across and entire face that could produce a leak path. Any scratches or dents that do not exceed 20% of the liner thickness can be eliminated by hand polishing with a fine abrasive cloth or paper.
6. If leakage occurs after the system has been cycled in an elevated temperature, it should be cool down to ambient temperature, to have a further inspection and maintenance.
7. No welding, brazing, soldering or flame cutting which can permanently damage the PTFE liner should be done close to the metal housings unless adequate precautions are taken to prevent exposure to excessive heat.
8. Safety vent holes should not be plugged with paint, cement, etc. The vent holes are essential to release gases that may be generated at elevated temperatures and trapped between the liner and the housing. If not vented these gases may collapse the liner. Vent holes also serve to warn of any accidental damage to the liner before leakage reaches dangerous proportions.

Table of Tightening the Bolts

Unit : kgf-m

Tightening Sequence for the Bolts

ANSI 150 LBS			JIS 10K		
NPS	MIN.	MAX.	NPS	MIN.	MAX.
1/2"	0.7	0.9	15mm	0.6	0.9
3/4"	0.9	1.3	20mm	0.8	1.2
1"	1.2	1.8	25mm	1.2	1.8
1-1/2"	1.9	2.9	40mm	1.9	2.9
2"	2.9	3.9	50mm	3.1	4.1
3"	3.3	5.4	80mm	3.6	5.6
4"	4.1	6.3	100mm	4.3	6.5
6"	8.0	12.2	150mm	8.4	12.6
8"	8.8	13.4	200mm	9.2	13.8
10"	10.6	15.2	250mm	10.2	14.8
12"	11.6	17.6	300mm	11.1	17.2
14"	14.6	19.8	350mm	13.6	18.8
16"	16.6	22.2	400mm	15.2	20.8
18"	18.6	24.4	450mm	17.2	22.8
20"	19.6	26.6	500mm	18.8	24.6

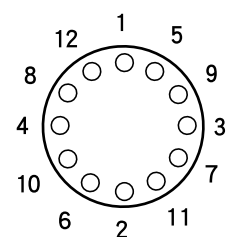
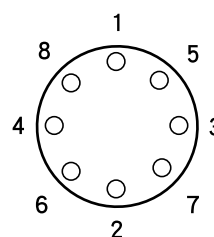
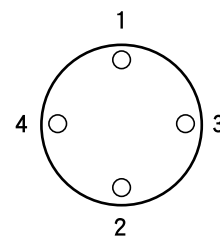



1. 電腦控制直管內襯系統

Computerized Lining Pipe System

- 自動控制內襯速度與受熱溫度一致性
Computerized lining speed with conformity of heating temperature.
- 增加直管品質穩定性
Enhance the stability of piping quality.



2. 電腦控制管件水壓 & 絕緣測試系統

Computerized Hydraulic & Mega Ohm Inspection System for Fittings.

- 此系統可做管件品質全檢
Full inspection quality may be done for fittings.
- 符合ASTM F1545內襯管件全面檢驗測試要求
The full inspection of lining fitting is in compliance with ASTM F1545
- 絕緣測試能提高管件產品之可靠度
The inspection of mega ohm will increase the reliability of all fitting products.



3. 電腦控制直管水壓 & 絕緣測試系統

Computerized Hydraulic & Mega Ohm Inspection System for Piping.

- 此系統可做直管品質全檢
Full inspection quality may be done for piping.
- 符合ASTM F1545內襯直管全面檢驗測試要求
The full inspection of lining piping is in compliance with ASTM F1545
- 絕緣測試能提高直管產品之可靠度
The inspection of mega ohm will increase the reliability of all piping products.







上品綜合工業股份有限公司
ALLIED SUPREME CORP.

● 總公司

台北市民族東路12號4樓

4TH FL., NO.12, MING-TSU E. RD., TAIPEI, TAIWAN, R.O.C.

TEL: +886-2-2597-6222 (REP) FAX: +886-2-2595-5626

Website: www.alliedsupreme.com